

Article

Mass Spectrometry Study of Reactive Species in a Microhollow Cathode Discharge In He+H₂O Mixtures

Yuya Katada¹, Singo Ikeno¹, Shota Murakami¹, Shinichi Namba¹, Tsutomu Yamasaki¹, Ken Takiyama^{1,*}, Kazutoshi Takenoshita², and Hideo Nojima²

¹ Graduate School of Engineering, Hiroshima University, Higashihiroshima, Hiroshima 739-8527, Japan

² Digital Appliances R&G Center, Samsung Electronics Co., Ltd., Suwon, Gyeonggi 443-742, Korea

*E-mail: takiyam@hiroshima-u.ac.jp

Abstract. Reactive species created by a microhollow cathode discharge (MHCD) in He+H₂O mixtures were investigated at 160 Torr using the molecular beam mass spectrometry. Ion fluxes of He⁺, HeH⁺, O⁺, OH⁺, H⁺(H₂O), and H⁺(H₂O)₂ were measured as functions of H₂O concentration (0.07-3.7%) and discharge current I_d (5-15 mA). When the concentration exceeds 1.5%, most of the ions were decreased, but H⁺(H₂O)₂ (cluster ion) significantly increased at $I_d=5$ mA, whose ion flux was low compared with those of other ions. With increasing I_d , the cluster ion showed a sharp decrease, while the other ions were almost constant. These features were reasonably explained by the increase of the gas temperature and the plasma rarefaction due to the Joule heating of the working gas.

Keywords: Microhollow cathode discharge, reactive species, mass spectrometry.

ENGINEERING JOURNAL Volume 17 Issue 5

Received 9 April 2013

Accepted 30 August 2013

Published 31 December 2013

Online at <http://www.engj.org/>

DOI:10.4186/ej.2013.17.5.29

This paper is based on the oral presentation at the 1st Joint Conference on "Renewable Energy and Nanotechnology" (JCREN 2012) in Bangkok, Thailand, 19-20 November 2012.

1. Introduction

In recent years radicals and ions created in non-thermal plasmas including water vapours, e.g., H, O, OH, and cluster ions $[H^+(H_2O)_m, O_2^-(H_2O)_n]$, have been gaining attention, because they can efficiently sterilize surfaces [1], medical instruments [2], air [3], food [4] and living tissues [5]. Microhollow cathode discharge (MHCD) is one of the most efficient ways to generate such plasmas in various kinds of gases at atmospheric pressure because of frequent collisions of high-density energetic electrons with gas molecules in the cathode cavity [6].

For a wide variety of applications of the MHCD plasmas, a large amount of reactive species should be generated at high efficiency. For this purpose, nonequilibrium high-density plasmas with a long-reaction cavity that ensures a long residence time of the working gas flow are required. Recently, we have found that the use of a microhollow cathode with a long cavity satisfying $2 \leq L/D \leq 6$ (L : length, D : diameter) enables us to generate stable negative glow plasmas over a wide range of working gas pressures up to atmospheric pressure, even under high-current-discharge conditions [7]. Moreover, the optical emission spectroscopy revealed that the plasma had high electron density of $(2-5) \times 10^{14} \text{ cm}^{-3}$ and low gas temperature of 400-800 K [8]. However, no systematic investigation has been done on reactive species generated in such high-density microplasmas. On the other hand, Bruggeman *et al.* have measured the reactive species generated in low density RF microplasmas using the optical emission spectroscopy and the molecular beam mass spectrometry, and examined their generation mechanisms using the Global model [9].

In this study, reactive species produced by a long-cavity MHCD in He+H₂O mixtures were investigated through the molecular beam mass spectrometry. Ion fluxes for various species were measured as functions of H₂O concentration and discharge current. On the basis of the observed dependences and discharge characteristics, atomic and molecular processes associated with the formation of the reactive species will be discussed.

2. Experimental

A sandwich-structured MHCD plasma source and a quadrupole mass spectrometer (QMS) are sketched in Fig. 1. The source, composed of three discs (a cathode of 2 mm thick, a ceramic spacer of 0.5 mm thick, and an anode of 1 mm thick), has a hole with a diameter of 0.4 mm. A flow of He-water-vapor mixture gas obtained by bubbling at room temperature (297 K) was provided at a constant rate of 0.2 L/min through the hole of electrodes. The gas pressure was kept constant at 160 Torr. The concentration of H₂O in the gas mixture was determined by using the internal ionization sources of QMS (ULVAC, CGM-052) in residual gas analysis mode. The discharge was operated with a DC voltage at a given discharge current I_d between 5 to 15 mA using a power supply with a ballast resistor 7.3 k Ω to generate MHCD.

For coupling to mass spectrometry, the vacuum chamber for QMS was differentially pumped by two-stage inlet system which were pumped down to 0.3 Torr and 1×10^{-5} Torr. The ions from the plasma are extracted through a skimmer cone installed at 5 mm from the edge of hollow cathode. The skimmer cone forms a molecular beam that minimizes the collisions of the sampled particles with each other [9]. The beam is directed into QMS, where the ions from the plasma are separated on the basis of their mass-to-charge ratio and a detector receives an ion signal proportional to the flux. It is noted that the internal ionization sources of QMS was not used in this measurement.

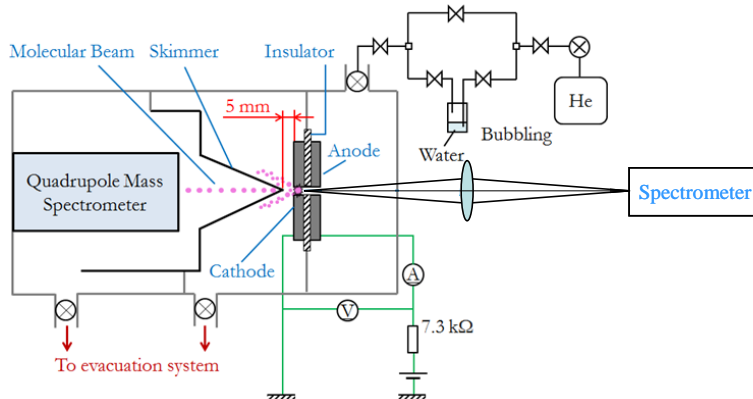

Fig. 1. Experimental setup.

3. Results and Discussion

3.1. Discharge Characteristics

Figure 2(a) presents the sustaining voltage, V_s , as a function of H_2O concentration under a constant discharge current. The obtained V_s was constant in the low concentration region, but increased remarkably when the concentration exceeded 0.27%. It is considered that the plasma resistance was increased, because negative ions were created in the plasma by the dissociative electron attachment with increasing water molecules [8, 10]. Figure 2(b) shows the I_d - V_s characteristics along with the input power under a constant H_2O concentration of 3.7%.

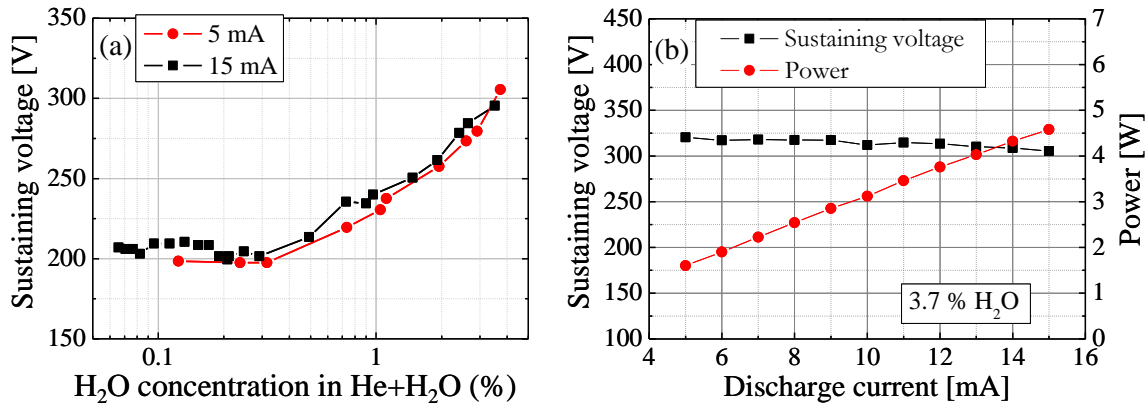

Fig. 2. Discharge characteristics: (a) sustaining voltage as a function of the H_2O concentration in $He+H_2O$ and (b) sustaining voltage and input power as a function of discharge current for 3.7% H_2O .

3.2. Mass Spectra of Generated Ions

Typical mass spectra of ions generated in MHCD under the conditions of (a) 0.07% H_2O and (b) 1.5% H_2O in $He+H_2O$ mixtures are shown in Fig. 3. In the case of low concentration, positive ions, He^+ , HeH^+ , He_2^+ , O^+ , OH^+ , and H_2O^+ , were observed, which were associated with constituent components of the mixture gas. In the case of high concentration, their ion fluxes were remarkably increased, and larger ions of $H^+(H_2O)$, HO_2^+ , $H_2O_2^+$ and $H^+(H_2O)_2$ newly emerged. It should be noted that $H^+(H_2O)_m$ type cluster ions are generated by hydration at this stage

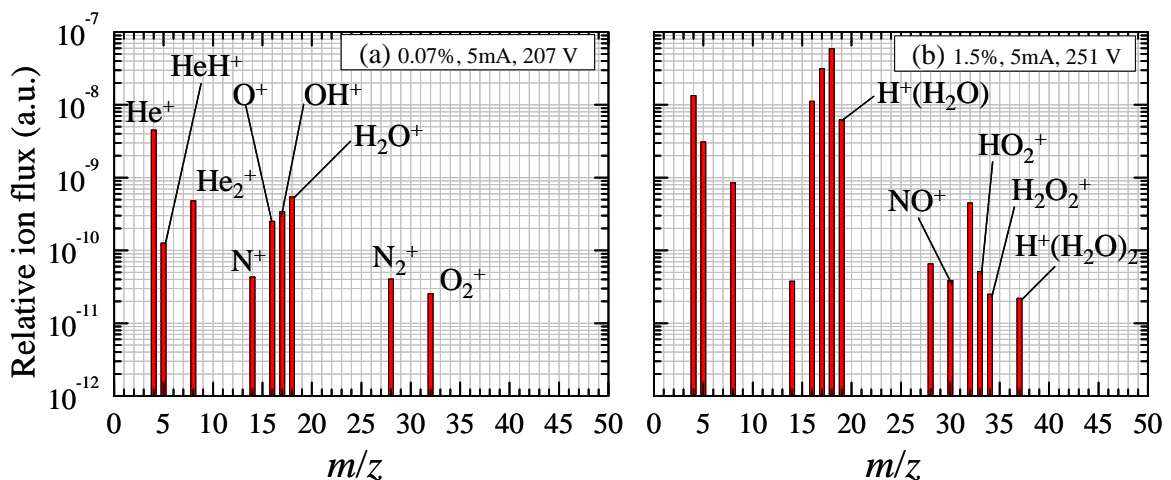

Fig. 3. Mass spectra of positive ions observed under discharge conditions of (a) 5 mA, 207 V for 0.07% H_2O and (b) 5 mA, 251 V for 1.5% H_2O in $He+H_2O$ mixtures.

3.3. Dependence of Positive Ion Flux on H₂O Concentration

In Fig. 4, ion fluxes observed at $I_d=5$ mA are depicted as a function of the H₂O concentration in He+H₂O. In the low concentration region (0.07–0.27%) where the gas pressure and V_s are kept almost constant, the fluxes of all ions are constant up to 0.17%, but show remarkable changes above 0.17%: Fluxes for He⁺ and ions associated with He gas, He₂⁺ and HeH⁺, steeply decrease up to 0.27%, whereas, those of the other ions, generated from H₂O, show gradual increase with H₂O concentration. This difference may result from that the increase of H₂O in He gas reduces the He⁺ production, because the cross section of electron impact ionization of H₂O [10] is much larger than that of He [11], for example, the value for He⁺ is $\sim 1/50$ for H₂O⁺ at $T_e \sim 25$ eV, where T_e is the electron temperature.

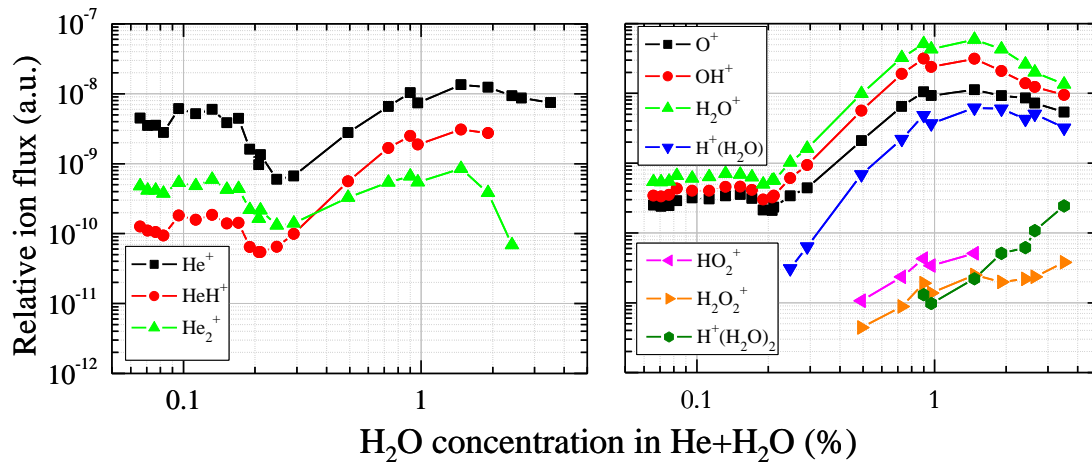

Fig. 4. Relative ion flux as a function of the H₂O concentration in He+H₂O at a discharge current of 5 mA and sustaining voltage of 200 to 296 V.

In the region of 0.27–1.0% all ion fluxes increased super-linearly with H₂O concentration. In this region, V_s also increases considerably with H₂O concentration, as shown in Fig. 2 (a). This suggests that the electron temperature increases, and then the cross sections for their electron impact ion generation steeply increase with T_e .

When the H₂O concentration exceeds 1.5%, the ion fluxes of almost all ions tend to decrease, although V_s still increases. This is possibly due to the decrease in the reaction cross-sections and the annihilation of their positive ions by recombining with negative ions, such as H⁻, O⁻, and OH⁻. However, only H⁺(H₂O)₂ is significantly increased, while H⁺(H₂O) is decreased. Considering that H₄O₂⁺ was undetectable, the formation mechanism for H⁺(H₂O)₂ is probably in the following:



where, R_{coeff} and T_g are the rate coefficient and the gas temperature, respectively, and M means a third body (abundant neutral species, e.g., He) [12].

Figure 5 shows ion fluxes observed at $I_d=15$ mA as a function of H₂O concentration. Ion flux reduction observed above 1.1% is similar to the case of 5 mA discharge. However, it should be emphasized that H⁺(H₂O)₂ was not observed, different from the 5 mA discharge case. The reason will be explained in section 3.4.

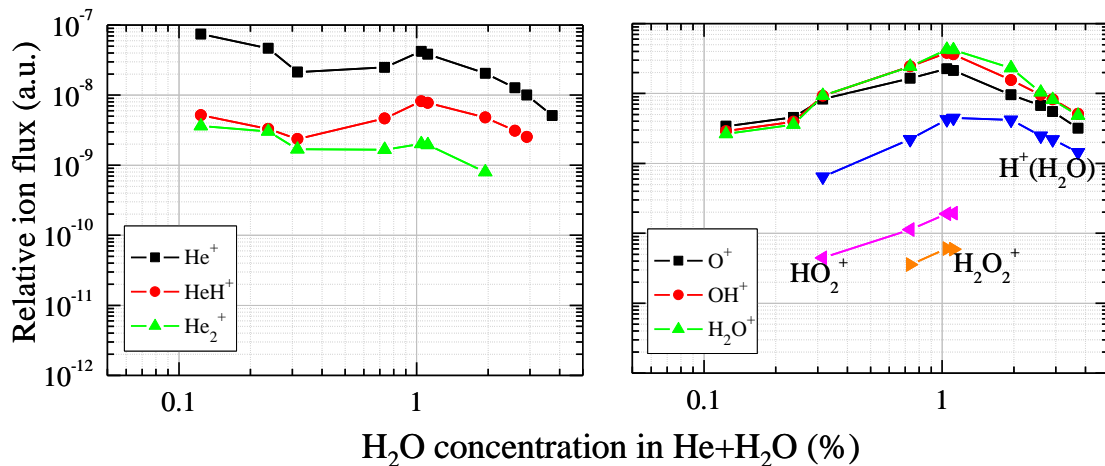

Fig. 5. Relative ion flux as a function of H_2O concentration in $\text{He}+\text{H}_2\text{O}$ at a discharge current of 15 mA and sustaining voltage of 199 to 309 V.

3.4. Dependence of Positive Ion Flux on Discharge Current

Ion fluxes at 3.7% H_2O in $\text{He}+\text{H}_2\text{O}$ are depicted as a function of I_d in Fig. 6. Most of ions showed constant or gradually decreasing ion flux with respect to I_d . Only $\text{H}^+(\text{H}_2\text{O})_2$ ions exhibited remarkable decrease. These features can be explained by the increase in T_g due to the Joule heating of the working gas [13]. As mentioned in section 3.3, the ions are formed from $\text{H}^+(\text{H}_2\text{O})$ according to the reaction (2), in which the reaction rate is dependent on T_g : when T_g increases, the formation rate will decrease. The efficiency of the production by the hydration of $\text{H}^+(\text{H}_2\text{O})$, $\eta(I_d)$, is defined as the ratio of ion flux of $\text{H}^+(\text{H}_2\text{O})_2$ to that of $\text{H}^+(\text{H}_2\text{O})$ at a given I_d . If we assume $T_g(5 \text{ mA})=300 \text{ K}$, then $T_g(12 \text{ mA})$ can be estimated to be $\sim 700 \text{ K}$ by putting the ratio of $\eta(12 \text{ mA})$ to $\eta(5 \text{ mA})$ equal to $(T_g/300)^{-4}$. The ratio, $T_g(12 \text{ mA})/T_g(5 \text{ mA})$, is in good agreement with that in the corresponding input electrical power [see Fig. 2(b)]. This suggests that the Joule heating can also cause thermal expansion of plasma volume which is proportional to T_g (rarefaction), since the gas pressure is constant. Consequently, the ion fluxes of He^+ , O^+ , OH^+ , H_2O^+ , and $\text{H}^+(\text{H}_2\text{O})$ were kept almost constant in spite of increasing I_d , as shown in Fig. 6.

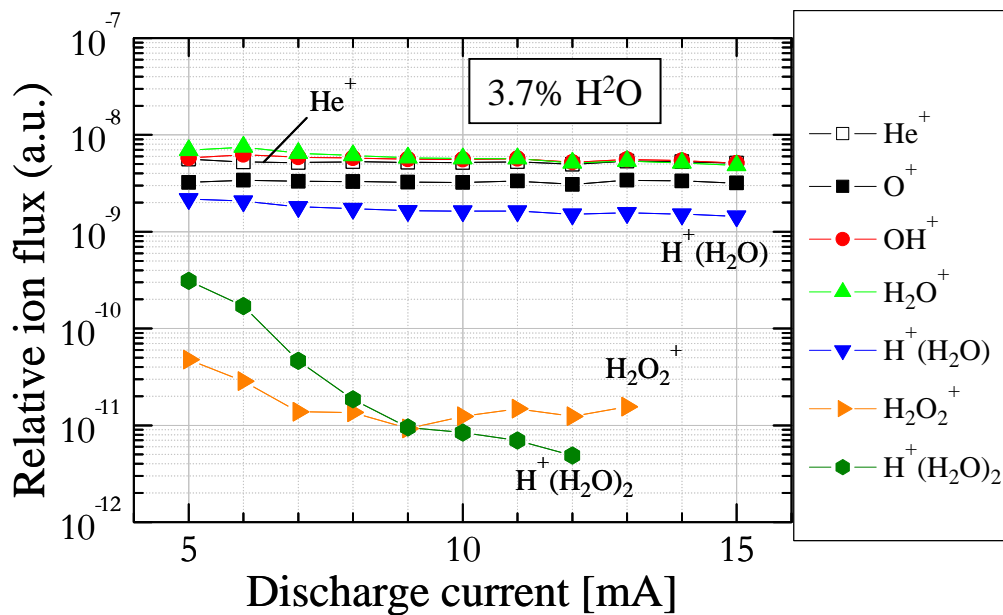

Fig. 6. Relative ion flux as a function of discharge current for 3.7% H_2O in $\text{He}+\text{H}_2\text{O}$.

4. Conclusion

Reactive species created by micro-hollow cathode discharges in He+H₂O mixtures were investigated at 160 Torr using the molecular beam mass spectrometry. Ion fluxes of He⁺, HeH⁺, O⁺, OH⁺, H⁺(H₂O), and H⁺(H₂O)₂ were measured as functions of H₂O concentration (0.07-3.7%) and discharge current I_d (5-15 mA). The fluxes of O⁺, OH⁺, and H⁺(H₂O) increased steeply with H₂O concentration from 0.19 up to 1.5%. Their increases are attributed to the increase of electron temperature due to the increase in sustaining voltage V_s , which may be caused by the decrease of free electrons through the electron attachment process. Exceeding 1.5%, their ion fluxes gradually decreased, although V_s still increased. On the other hand, a cluster ion, H⁺(H₂O)₂, emerged at 0.9% and significantly increased up to 3.7%, whose ion flux was considerably low compared with those of dominant ions. We found that this ion was generated by the hydration of H⁺(H₂O) according to the reaction (2). With increasing I_d at 3.7%, the cluster ion showed a sharp decrease, while the other ions gradually decreased. These phenomena were reasonably explained by the increase of the gas temperature and plasma rarefaction caused by the Joule heating of the working gas.

References

- [1] F. Rossi, O. Kylián, H. Rauscher, M. Hasiwa, and D. Gilliland, "Low pressure plasma discharges for the sterilization and decontamination of surfaces," *New Journal of Physics*, vol. 11, no. 11, p. 115017 2009.
- [2] O. Kylián and F. Rossi, "Sterilization and decontamination of medical instruments by low-pressure plasma discharges: Application of Ar/O₂/N₂ ternary mixture," *Journal of Physics D: Applied Physics*, vol. 42, no. 8, 2009.
- [3] S. Müller and R. J. Zahn, "Air pollution control by non-thermal plasma," *Contributions to Plasma Physics*, vol. 47, no. 7, pp. 520-529, 2007.
- [4] S. Hati, S. Mandal, S. Vij, P. S. Minz, S. Basu, Y. Khetra, D. Yadav, and M. Dahiya, "Nonthermal plasma technology and its potential applications against foodborne microorganisms," *Journal of Food Processing and Preservation*, vol. 36, no. 6, pp. 518-524, 2012.
- [5] A. Shashurin, M. Keidar, S. Bronnikov, R. A. Jurjus, and M. A. Stepp, "Living tissue under treatment of cold plasma atmospheric jet," *Applied Physics Letters*, vol. 93, no. 18, 2008.
- [6] K. H. Becker, K. H. Schoenbach, and J. G. Eden, "Microplasmas and applications," *Journal of Physics D: Applied Physics*, vol. 39, no. 3, pp. R55-R70, 2006.
- [7] T. Yamasaki, S. Namba, K. Takiyama, and H. Nojima, "Effect of cathode length on electrical characteristics of a microhollow cathode discharge in helium," *Japanese Journal of Applied Physics*, vol. 51, p. 066001, 2012.
- [8] T. Yamasaki, S. Namba, K. Takiyama, and H. Nojima, "Pressure dependences of gas temperature and electron density in microhollow cathode discharges in He and He+H₂O gases," *Japanese Journal of Applied Physics*, vol. 51, p. 126101, 2012.
- [9] P. Bruggeman, T. Verreycken, M. Á. González, J. L. Walsh, M. G. Kong, C. Leys, and D. C. Schram, "Optical emission spectroscopy as a diagnostic for plasmas in liquids: Opportunities and pitfalls," *Journal of Physics D: Applied Physics*, vol. 43, no. 12, 2010.
- [10] Y. Itikawa and N. Mason, "Cross sections for electron collisions with water molecules," *Journal of Physical and Chemical Reference Data*, vol. 34, no. 1, pp. 1-22, 2005.
- [11] R. C. Wetzel, F. A. Baiocchi, T. R. Hayes, and R. S. Freund, "Absolute cross sections for electron-impact ionization of the rare-gas atoms by the fast-neutral-beam method," *Physics Review A*, vol. 35, no. 2, pp. 559-577, 1987.
- [12] D. X. Liu, P. Bruggeman, F. Iza, M. Z. Rong and M. G. Kong, "Global model of low-temperature atmospheric-pressure He+ H₂O plasmas," *Plasma Sources Science and Technology*, vol. 19, no. 2, 2010.
- [13] M. J. Kushner, "Modelling of microdischarge devices: Plasma and gas dynamics," *Journal of Physics D: Applied Physics*, vol. 38, no. 11, pp. 1633-1643, 2005.