

# REVIEWS ON SOLID OXIDE FUEL CELL TECHNOLOGY

Navadol Laosiripojana<sup>a</sup>, Wisitsree Wiyaratn<sup>b</sup>,  
Worapon Kiatkittipong<sup>c</sup>, Arnornchai Arpornwichanop<sup>d</sup>,  
Apinan Soottitantawat<sup>d</sup>, and Suttichai Assabumrungrat<sup>d,\*</sup>

<sup>a</sup> The Joint Graduate School of Energy and Environment,  
King Mongkut's University of Technology Thonburi, Bangkok 10140, THAILAND

<sup>b</sup> Department of Production Technology Education,  
Faculty of Industrial Education and Technology,  
King Mongkut's University of Technology Thonburi, Bangkok 10140, THAILAND

<sup>c</sup> Department of Chemical Engineering, Faculty of Engineering and Industrial Technology,  
Silpakorn University, Nakhon Pathom 73000, THAILAND

<sup>d</sup> Department of Chemical Engineering, Faculty of Engineering,  
Chulalongkorn University, Bangkok 10330, THAILAND

\* Corresponding author (Suttichai.A@chula.ac.th)

## ABSTRACT

Solid Oxide Fuel Cell (SOFC) is one type of high temperature fuel cell that appears to be one of the most promising technology to provide the efficient and clean energy production for wide range of applications (from small units to large scale power plants). This paper reviews the current status and related researches on SOFC technologies. In details, the research trend for the development of SOFC components (i.e. anode, electrolyte, cathode, and interconnect) are presented. Later, the current important designs of SOFC (i.e. Seal-less Tubular Design, Segmented Cell in Series Design, Monolithic Design and Flat Plate Design) are exemplified. In addition, the possible operations of SOFC (i.e. external reforming, indirect internal reforming, and direct internal reforming) are discussed. Lastly, the research studies on applications of SOFCs with co-generation (i.e. SOFC with Combined Heat and Power (SOFC-CHP), SOFC with Gas Turbine (SOFC-GT)) and SOFC with chemical production) are given.

## KEYWORDS

SOFC; SOFC component; SOFC design; Cogeneration

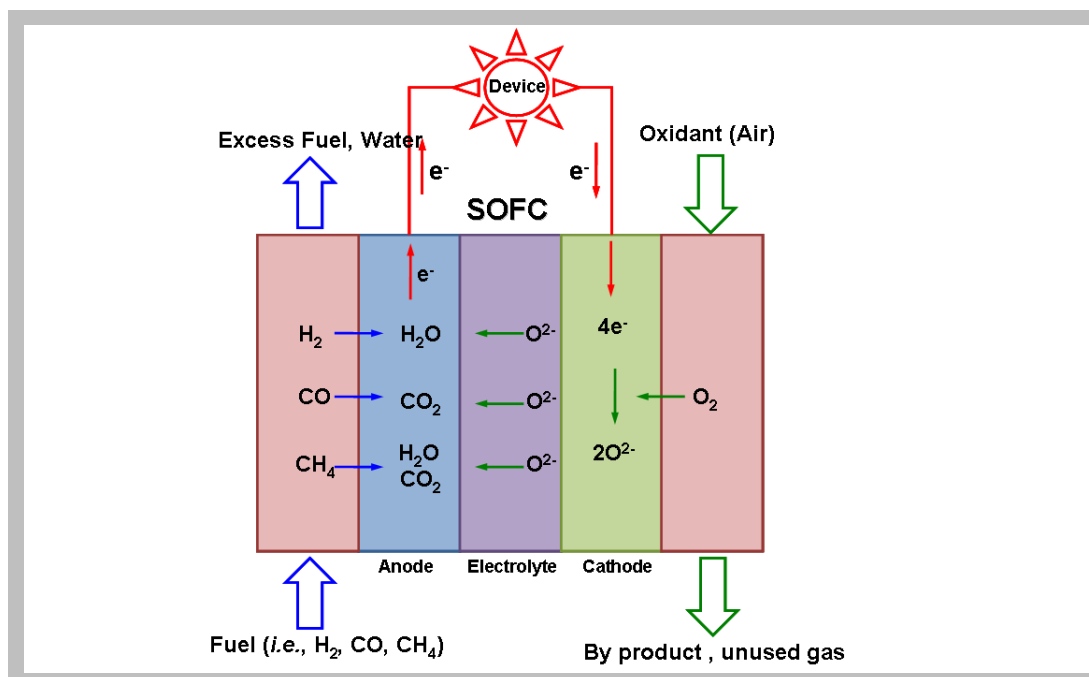
# I . Introduction of SOFC

Fuel cell is an energy conversion unit that converts a gaseous fuel to electrical energy and heat by electrochemical combination of a fuel with an oxidant. Since it is operated electrochemically and is not limited by the Carnot cycle, lower emissions such as  $\text{NO}_x$  or  $\text{CO}_2$  are produced from fuel cells compared to the cleanest combustion process [1]. Due to its high conversion efficiency and environmental acceptability, the fuel cell is regarded as an effective process to produce electricity from chemical components. Moreover, this technology also presents flexibility and modularity, as it does not suffer appreciably from problems of lubrication, wear, leakage and heat loss, which affect the reliability of traditional heat engines [1].

Typically, fuel cell consists of three main sections: anode, electrolyte and cathode. A fuel and an oxidant, supplied from external sources, are introduced to the anode and cathode side, respectively. Both could be any gases capable of being electrochemically oxidised and reduced. The driving force of the operation is the chemical potential gradient of ions across the electrolyte. Direct-current electricity was consequently produced in the external circuit. In the real application, fuel cells are connected in a series of cells in order to obtain higher outlet voltage. An interconnect plate is always installed to provide the electronic contact between the anode of one cell and the cathode of the next cell [2].

Solid Oxide Fuel Cell (SOFC) is a type of fuel cell that appears to be one of the most promising fuel cell systems. This type of fuel cell is the main focus of the reviews. SOFC has been particularly of interest due to its high operation temperature and fuel management [3]. Similar to other type of fuel cells, SOFC requires the fuel such as hydrogen, and oxidant reactants such as oxygen or air to electrochemically react at high temperature and generate electrical energy. Hydrogen is normally used as the fuel since it has high electrochemical activity, but carbon monoxide can be also used as the fuel together with hydrogen. The direct use of a hydrocarbon gas instead of hydrogen or carbon monoxide is also possible when operated as internal reforming. Figure 1 shows the principle of electrochemical cell for SOFC.

SOFC has several advantages over other type of fuel cells. It is able to convert carbon monoxide as well as hydrogen, and the high operating temperature allows internal reforming of gaseous fuel and promotes rapid kinetics to produce high quality heat for energy conversion. However, there are some disadvantages of this type of fuel cell; i.e. several requirements on its ceramic materials, such as the stability in oxidising and reducing conditions, chemical compatibility with various ceramics employed, thermal expansion compatibility of various components over the large temperature range, and adequate ionic conductivity of the membrane [4]. In addition, because of the high operating temperature, long waiting times for heat up and cool down cycles are required in order to minimize the structural stresses caused by the expansion and contraction of materials in the cell, which expand and contract at different rates.



**Figure 1**  
Principle of electrochemical SOFC.

## II. Materials for SOFC

The main advantage of SOFC over other types of fuel cell is its tolerance to the impurities of inlet fuels; this means various type of fuel can be applied with SOFC. It is noted that the fuel flexibility is mainly due to its high operating temperature (c.a. 1000 °C). However, at the high operating temperature there are some limitations to SOFC especially the materials used, *i.e.*, materials component should be durable to high temperature without unchanged of the required properties. Thus, until now, there have been several researches to develop and fabricate materials to meet requirements of SOFC [5].

### 2.1 Fuel Cell components

Figure 2 shows the schematics of SOFC for their stack configuration. The main components of a single cell are electrolyte, cathode and anode. When single cells are stacked together to generate more power, two more cell components of interconnect and sealant are required. The solid electrolyte is between the electrode (anode and cathode) to conduct the ions of  $O^{2-}$  but not conduct electron, thus the current passes through the device via the external circuit. The fuel is oxidized at the anode and the oxygen is reduced at the cathode.

At the present, the state-of-the art SOFC cell components materials are: 8 mol% yttria stabilized zirconia (YSZ, electrolyte), Sr-substituted  $LaMnO_3$  (LSM, cathode), Ni-YSZ cermet (anode), Ca-substituted  $LaCrO_3$  (LCR) or metallic alloys (interconnect) and glass or glass-ceramic (sealants). The actual used of typical SOFC structure as shown in Figure 3.

### 2.2 Solid Electrolyte

Electrolyte, an ion-conducting ceramic, is a main component of SOFC. It may carry either oxide-ion ( $O^{2-}$ ) or proton ( $H^+$ ). However, there are the required properties of the oxides for using as SOFC electrolyte materials [7].

- High oxide ion (or proton) conductivity ( $0.01-0.1 \text{ S cm}^{-1}$  for the thickness 1-100  $\mu\text{m}$ .) Low oxide ion conductivity resulting higher ohmic loss.
- Low electronic conductivity: Higher electronic conduction causes higher voltage loss and oxygen leakage without producing electricity.
- Chemical stability: They should have the stability either in the thermal stability in air and fuel and stability under the oxygen potential gradient.
- Mechanical strength. (Stress)
- Low cost for both of raw materials and the processing.

There are many challenge materials which have been applying as electrolyte materials. The relation between ion conductivity of potential materials and temperature are shown in Figure 4 [8, 10]. As mentioned earlier, yttria-stabilized zirconia (YSZ) is the most widely used electrolyte for SOFC. Scandia stabilized zirconia (ScSZ) shows higher conductivity compared to YSZ. It also shows excellent stability in oxidizing and reducing environment with better long-term stability than YSZ. However, the problem for the implementation of this material is the prices and availability of scandia [9].

Gadolinia-Doped Ceria (GDC) or cerium gadolinium oxide (CGO) shows higher conductivity than YSZ and ScSZ especially at low temperature. Therefore, this material has great potential for application in an intermediate-temperature SOFC (IT-SOFC). The primary challenge GDC is its stability at low-oxygen partial pressure which shows mixed electronic and ionic conductor even at low oxygen concentration [11]. However, its major limitations are the low electronic conduction at low partial pressure of oxygen, their mechanical stability and also the price and availability of Gd. Another interesting electrolyte material is perovskite-based lanthanum gallate,  $LaGaO_3$  doped with strontium on the lanthanum site and magnesium on the gallium site ( $(La_{1-x}Sr_x)(Ga_{1-y}Mg_y)O_3$ , LSGM). As seen in Figure 4, it also shows great potential to be used at low operating temperature due to its high ion conductivity at low

temperature. It is noted that Joshi et al. [11] reported the maximum conductivity of  $(\text{La}_{1-x}\text{Sr}_x)(\text{Ga}_{1-y}\text{Mg}_y)\text{O}_3$  at 20 % Sr and 15-20 % Mg. Nevertheless, the limitation of this electrolyte is the phase stability, Ga-evaporation at low-oxygen partial pressure. In addition, it is also incompatible with NiO, which generally applied as anode materials. Furthermore, its mechanical stability, availability and price of Ga are also limitation of its use [9].

## 2.3 Electrode

The electrode of SOFC consists of 2 parts i.e. anode and cathode. Details of each type of electrode are given below. It is noted that the important properties of electrode are [7]:

- Catalytic activity (for oxygen dissociation and incorporation reactions in cathode and for electrochemical oxidation of  $\text{H}_2$  or CO and others fuel processing in anode)
- Electronic (preferable: ionic) conductivity (electrode conductivity should be higher than  $10 \text{ S cm}^{-1}$ )
- Chemical Stability and compatibility
- High morphological stability without sintering
- Mechanical compatibility with the other materials i.e. electrolyte and interconnect; thermal expansion mismatch may cause the break down of the cell.
- Low cost

### Anode

The anode materials must be compatible (chemical and thermal expansion) with electrolyte and provide means for transport of gas from fuel, oxygen ions from electrolyte and electrons to interconnect. The catalytic properties of the anode to the oxidation of fuel are also important [12].

The most common anode material is a porous Ni-YSZ cermet, in which nickel provides the electronic conductivity and YSZ provides the oxygen-ion conduction. The cermet is prepared by dissolving the NiO in the YSZ. The dissolved nickel is stable in the YSZ thus the degradation from its reaction could be rarely observed. The main degradation of Ni-YSZ cermet is from its changes of morphology, i.e. size and shape changing from the sintering. Furthermore, if inlet hydrocarbon fuels are applied, the catalytic activity of Ni-YSZ could be easily destroyed from the carbon deposition. In addition, the poisoning from sulfur impurities in the feed is another major problem for Ni-YSZ [13, 14]. Regarding these limitations of Ni-YSZ, Cu-YSZ is another good candidate to be used as anode material since Cu does not catalyze the C-C bond of carbon deposition and also more tolerance to sulfur impurities than Ni-YSZ [15]. However, it is not stable at SOFC operating conditions.

Strontium titanate ( $\text{SrTiO}_3$ ) has also been proposed as an alternative anode materials. It is chemically stable and shows electronic conduction upon reduction due to the presence of  $\text{Ti}^{3+}$ . Like other perovskites its electrical conductivity could be enhanced by donor doping with tri or pentavalent oxides such as  $\text{La}^{3+}$ ,  $\text{Y}^{3+}$  or  $\text{Nb}^{5+}$  [9]. Importantly, although chemical reaction between perovskite anodes and YSZ is generally not the problem, if other perovskite e.g. LSGM is used as electrolyte, the diffusion of doping molecule could be occurred between each peroskie for example gallium or magnesium from LSGM electrolyte could diffuse to  $\text{SrTiO}_3$  anode [10].

### Cathode

The most common type of cathode material is perovskite-based  $\text{LaMnO}_3$ . Furthermore, strontium is normally used to dope with  $\text{LaMnO}_3$  (become  $(\text{La}_{1-x}\text{Sr}_x)\text{MnO}_3$  (LSM)), which can enhance the electronic conductivity. The thermal expansion coefficient of LSM matches well with that of YSZ [10], however, its ion conductivity is relatively low. Therefore, there have been several studies on the increasing of LSM conductivity as well as its electrolyte close thermal expansion, i.e., Co was used instead of  $\text{MnO}_3$  with the doping of Fe [10]. The reaction between YSZ electrolyte and LSM cathode normally occurs during the processing, resulting in the  $\text{La}_2\text{Zr}_2\text{O}_7$  and/or  $\text{SrZrO}_3$  [16, 17]. Ceria-based interlayer is often used to prevent reaction between YSZ and cathode due to the stability of ceria for both YSZ and cathode materials [18].

## 2.4 Interconnects

The interconnect material is in contact with both electrodes, thus it must be stable in both oxidizing and reducing atmospheres [19]. Furthermore, it must be an electronic conductor and have similar characteristics to that of electrolyte [7]. In addition to chemical compatibility, the coefficient of thermal expansion must be matched with the other cell components to avoid the generation of stress at the operating condition. Materials and fabrication cost are also important for the cost-effective production of fuel cells [19].

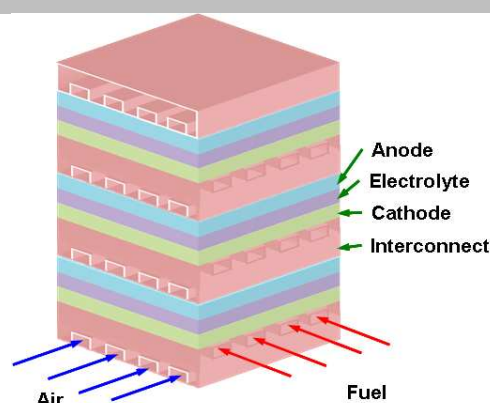
SOFC interconnect could be either ceramic or metals/alloys materials. Ceramic interconnects are normally used between 800 and 1000°C, whereas metallic interconnects are preferred at 750 °C or below [9]. The doped  $\text{LaCrO}_3$  is normally used as ceramic interconnects. The dopants are typically strontium or calcium to increase the conductivity [10]. The ceramics interconnects are generally stable with YSZ electrolyte. However, the limitations of their uses are the high cost and the decreasing of conductivity with decreasing temperature. Therefore, the metallic interconnects are also developed which typically are Cr-based alloys and ferritic steels. They have a number of advantages over ceramic interconnects, for examples, extremely high electrical conductivity, high thermal conductivity and enhancement of the ability to accommodate thermal stresses [9]. The chromium based alloys are attractive with dispersing of stable oxides but are relative costly to fabricate. At the present, thus, the ferritic stainless steels are the most attractive metallic interconnect for SOFC [19]. However, the metallic interconnects is suffer from some drawbacks such as the electrical contacts between metallic interconnect and ceramic electrodes, matching of thermal expansion, oxide scale formation on the metallic surface as well as cathode poisoning [9].

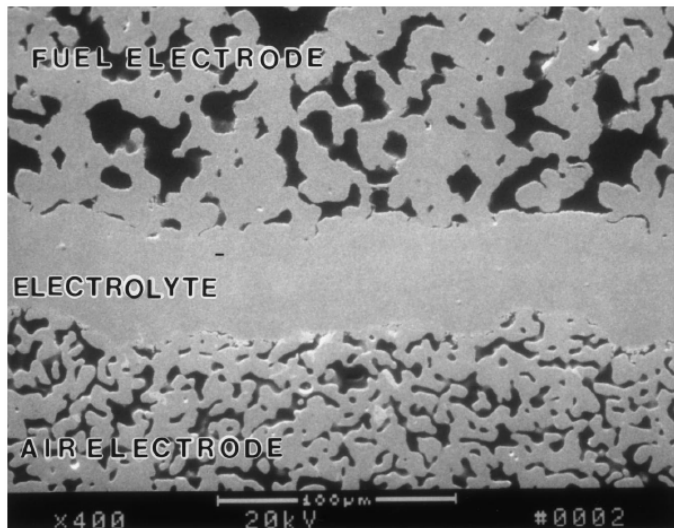
## 2.5 Sealant

The sealants need to fulfill all the criteria for all of components. They must be stable in a wide range of oxygen partial pressure (air and fuel) while minimizing thermal stresses during high-temperature operation. The quality of seals must be high, since even small leaks in these seals can affect the cell potential, resulting in the reduction of performance [20]. Sealant development is additionally complicated because the optimal sealant depends on the materials of other components.

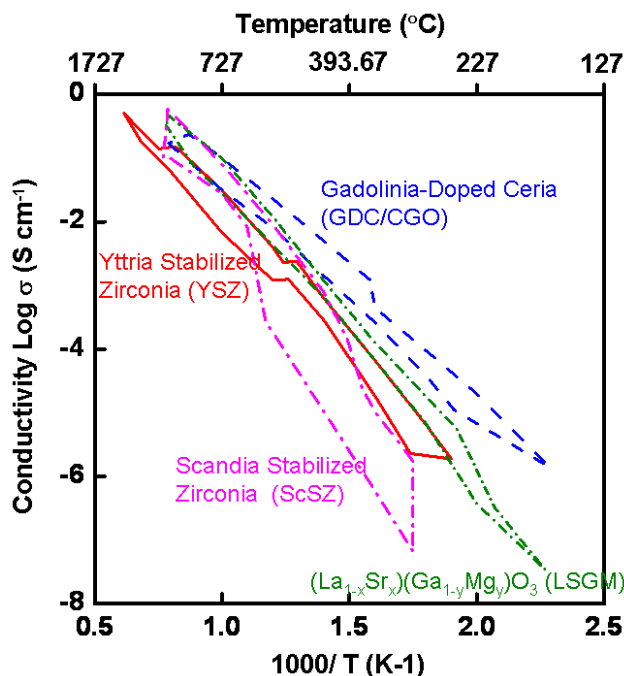
The rigid and compressive seals are being developed for SOFCs. A major advantage of compressive seals is that the seals are not rigidly fixed to the other SOFC components thus the exactly match of thermal expansion is not required but the load must be applied continuously during operation. The compressible seals are normally the metal gaskets, i.e. silver, as well as the mica-based materials. The infiltration of mica base materials can be applied to improve their properties which the infiltration, i.e. silver, glass, silica or talc, can block the gaps between the mica flakes [10]. Rigid seals, on the other hand, do not require the continuous load but the thermal expansion must closely match those of other SOFC components [10, 20]. Glasses and glass ceramics are typically used as rigid seals [20]. The thermal expansion of most rigid glass seals are lower than YSZ electrolytes, thus, the barium and calcium are added so that the orthosilicate phases are formed with high thermal expansion [10]. Metallic brazes are also used as rigid seals and were accommodating of stress than ceramics. The challenges of metallic seals are cost and its wetting of the ceramic components.

**Figure 2**  
Schematic design of  
SOFC stack  
configuration.





**Figure 3**  
Microstructure of a cross-section of a Siemens Westinghouse SOFC [6].



**Figure 4**  
Quantum Dot Rings (QDRs) are also obtained by droplet epitaxy at droplet thickness of 3.2 ML

### III. Designs of SOFC

Several types of SOFC configurations have been proposed. The differences among these designs are the method of connecting between each cell, the shape of each cell, or the flowing of fuel and oxidant through their channels.

#### Seal-less Tubular Design

This configuration was proposed by Westinghouse Electric Corporation in 1980. It consists of a tubular support tube, which covers with cathode, electrolyte, anode, and interconnection [21, 22] as shown in Figure 5.

The oxidant is introduced through the centre of the support tube, whereas the fuel flows at the outside of this support tube. The main advantage of this configuration is the elimination of the gas-tight seal problem, as this design has no seal between each cell. However, this SOFC design has some disadvantages such as the cell internal resistance and the gas diffusion limitation.

## Segmented Cell in Series Design

Similar to Seal-less Tubular Design, a tubular porous support tube is deposited with anode, electrolyte, cathode, and interconnection materials. However, in this design, fuel is introduced through the centre of the support tube, while the oxidant flows at the outside of the support tube. In addition, individual segmented cells are connected to each other in series [23-36].

## Monolithic Design

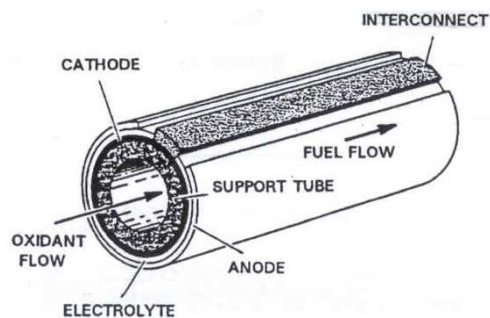
This SOFC design is similar to shell-and-tube heat exchanger design, as it utilises thin cell components including anode, electrolyte, cathode, and interconnection into a compact corrugated structure. There are two different configurations for this SOFC design, which are gas co-flow and gas cross-flow configurations [27, 28] as shown in Figure 6 (a) and (b) respectively.

In the first configuration, gas co-flow arrangement, fuel and the oxidant flow parallel in corrugated channels that formed by anode/electrolyte/cathode multilayer ceramics. Individual corrugated plates are then connected to adjacent plates by a flat anode/interconnection/cathode multilayer ceramics. In the gas cross-flow arrangement, the corrugated fuel channels are anode ceramic plate, while the corrugated oxidant channels are cathode ceramic plate. These corrugated plates are connected to each other by an anode/electrolyte/cathode multilayer ceramic. These plates are then connected to adjacent plates by a flat anode/interconnection/cathode multilayer ceramics. The advantages of this design are compact cells, self-supporting corrugated structures, and thin cell components. However, the main problem of this design is the fabrication of materials. Any difference in the thermal expansion coefficients can result in cell cracking.

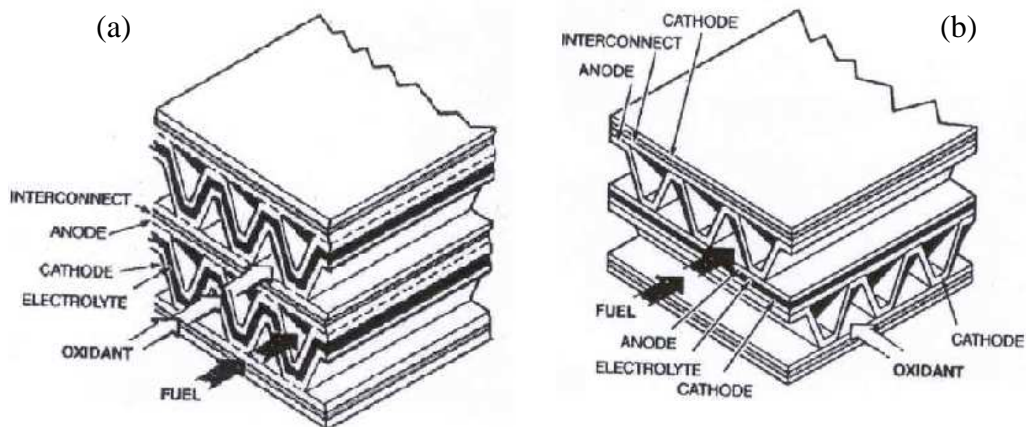
## Flat Plate Design

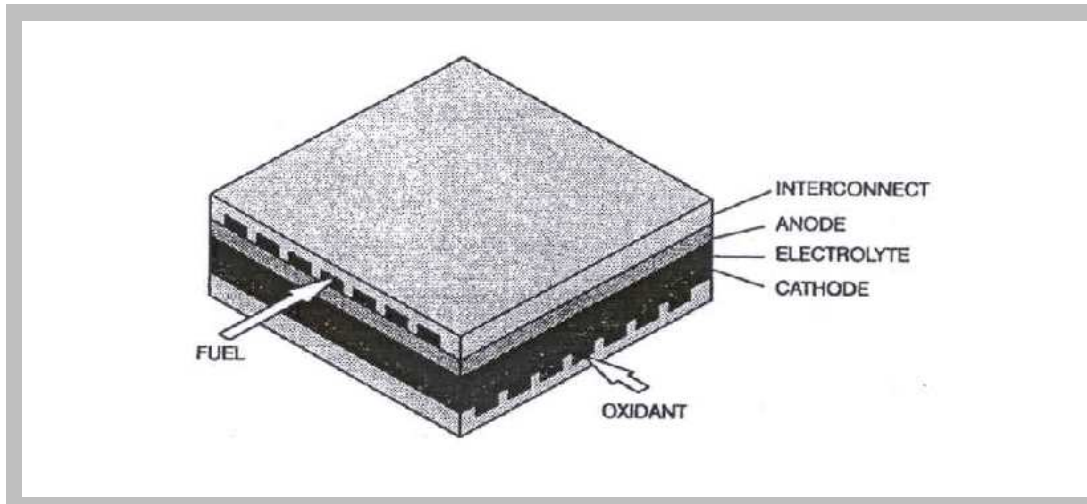
Unlike Monolithic Design, the flat multilayer ceramic plate composing of anode, electrolyte, and cathode is used in this design. This flat multilayer ceramic plate is covered with interconnect plates, which have small gas flow channels for fuel and the oxidant. Figure 7 shows this SOFC design [2].

**Figure 5**  
Seal-less tubular  
SOFC design [21].



**Figure 6**  
Monolithic SOFC; (a)  
coflow configuration,  
(b) crossflow  
configuration [2].





**Figure 7**  
Flat plate SOFC [2].

## IV. Operation of SOFC

As described earlier, hydrogen and carbon monoxide are used as the fuel for SOFC. In order to supply these components to the fuel cell, the steam reforming reaction is always used to reform hydrocarbon fuels such as natural gas. Due to the high operating temperature of SOFC, the steam reforming occurs very efficiently.

In general, SOFC consists of two main sections: a reformer part where the reforming reaction takes place, and a fuel cell part where the electrochemical reactions occur. The external feed such as methane (in natural gas) is converted to hydrogen and carbon monoxide at the reformer section. In external reforming, the endothermic steam reforming reaction and the fuel cell reactions are operated separately in the different units, and there is no direct heat transfer between both unit operations, Figure 8.

In contrast, for internal reforming, the endothermic reaction from the steam reforming reaction and the exothermic reaction from the oxidation reaction are operated together in the single unit. Therefore, the requirement for a separate fuel reformer is eliminated, and this configuration is expected to simplify the overall system design, making SOFC more attractive and efficient means of producing electrical power [3]. There are two internal reforming concepts; these are referred to as Direct Internal Reforming (DIR) and Indirect Internal Reforming (IIR) as shown in Figure 9(a), and (b) respectively.

For DIR operation, the reforming reaction takes place at the anode of the fuel cell. Heat and steam are supplied directly from the electrochemical reaction, which also helps to complete the reforming reaction by removing and using of hydrogen. The main advantage of this type of operation is that the hydrogen consumption by the electrochemical reaction could directly promote the conversion of methane at the anode side of the fuel cell. Therefore, DIR results in high conversion and high efficiency. However, this type of operation also requires an anode material that has good catalytic properties for reforming reaction and electrochemical reactions. Moreover, carbon formation at the anode side could occur due to the high operating temperature and lead to the loss of cell performance and poor durability.

For IIR operation, the reforming reaction takes place at the reformer, which is in close thermal contact with the anode side of fuel cell. IIR gives the advantage of good heat transfer between the reformer and the fuel cell. The heat transfer between these two reactors is expected to provide an autothermal operation. However, unlike DIR operation, the reformer part and the anode side for IIR operation are operated separately. Therefore, the catalyst for reforming reaction at the reformer part and the material for electrochemical reactions at the anode side of fuel cell can be different and optimized individually.

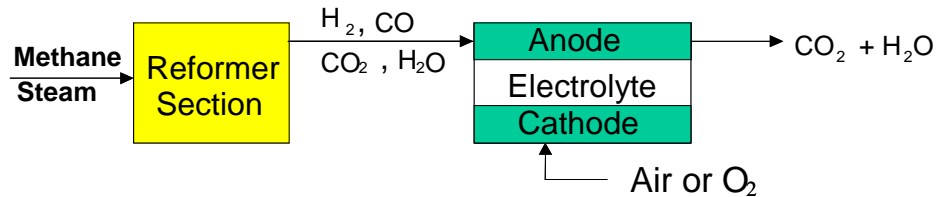
The main problem of internal reforming operation is the mismatch between the heat requirement for steam reforming reaction and the heat available from the fuel cell section. At SOFC temperatures, the kinetics of the reforming reactions are extremely high. Although they are limited by mass and heat transfer consideration, they are still much higher than the corresponding fuel cell reactions. Therefore, the internal reforming operation could lead to local subcooling around the entrance area of reformer part (inhomogeneous temperature



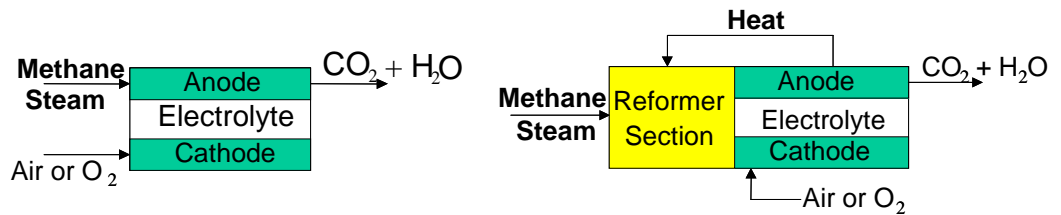
distributions), which can result in mechanical failure due to thermally induced stresses [29]. An additional problem related with the direct internal reforming (DIR) is carbon deposition on the anode side, which occurs due to the cracking reaction. The carbon formation could result in the deactivation of anode material, which leads to the loss of fuel cell performance. The quantity of carbon deposited on the anode is affected by the operating temperature and the methane to steam ratio [30].

The further disadvantages of internal reforming operation compared with external reforming operation are: conventional fuel cell materials might be poisoned by some impurities (e.g., sulfur components) in the feed fuel, or by sintering of the active metal and/or support at high temperature. In addition, integration of the combination between the reforming and electrochemical reactions might reduce the flexibility of the fuel cell operation, this disadvantage is likely to be more concerned problem with DIR operation compared with IIR.

**Figure 8**  
External steam reforming operation for SOFC.



**Figure 9**  
(a) Direct Internal Reforming (DIR), and  
(b) Internal Reforming (IIR) operation.



## V. Applications of SOFC

In general, SOFC system for a distributed power generation consists of three main parts [31]: (1) a fuel processor to reform hydrocarbon fuels to hydrogen-rich gas, (2) an SOFC stack where the electric power is generated, and (3) a power conditioner for converting the DC power to utilizable AC power. Since the cell voltage drops with decreasing fuel concentration within cell stack, the SOFC is practically operated at the fuel utilization of 80-95% for better energy efficiency [32, 33] and thus the outlet gas from a cell stack contains valuable residual fuel. Furthermore, due to the high temperature operation (up to 1000°C) and the irreversible electrochemical process of SOFC, a waste heat is also produced in the cell power section [34]. As a result, the utilization of the high-quality heat and the remaining fuel existing SOFC can further improve the efficiency of the SOFC system. This brings the SOFC system to a combined process with other types of bottoming cycles such as a gas turbine (GT) for additional electric power generation [35, 36]. In addition, the waste heat can be utilized as a heat source for the system through a series of heat exchangers. The cogeneration of heat with electricity (a combined heat and power system) can increasingly enhance the SOFC system performance as well. Figure 10 shows a simplified schematic diagram of SOFC and its interconnections.

### 5.1 Cogeneration of SOFC: Combined Heat and Power (SOFC-CHP)

As mentioned earlier, the high-quality of waste heat and electrical energy can be cogenerated in SOFC systems. For the SOFC-CHP, the heat content of the outlet gas from a combustion process of unused fuel exiting a fuel cell stack with air in a combustion chamber (sometime called an afterburner) is recovered and provided to other parts in the SOFC system as demonstrated in Figure 11.

In a practical cell operation, the useful heat from the SOFC is usually exploited in energy-requiring units, i.e., preheaters and reformers, to preheat cooling streams or to generate steam and hot water. A number of research efforts have been focused on the integration of SOFC with CHP and various configurations of the SOFC system have been explored. For examples, Chan et al. [37] examined a SOFC power system fed by hydrogen and methane. The H<sub>2</sub>-fed SOFC system incorporated two preheaters, an SOFC stack, and an afterburner, whereas the CH<sub>4</sub>-fed SOFC system showed a slightly more complex plant that consisted of a mixer, a vaporizer, two preheaters, an external reformer, an SOFC stack, and an afterburner. In case of the CH<sub>4</sub>-fed SOFC system, the unreacted fuel from the cell stack was burnt in the afterburner and the heat generated was supplied to the reformer, vaporizer, and preheaters. The simulation results showed that the efficiency of the CH<sub>4</sub>-fed system was higher than that of the H<sub>2</sub>-fed system. Fontell et al. [38] studied a 250 kW natural gas-fuelled SOFC plant. A desulphuriser unit was included in the system to treat natural gas before being fed to SOFC stack as sulphur is harmful to the SOFC stack. Figure 12 shows the proposed SOFC system in which the outlet anode gas is used for preheating a reformed fuel and is then split into two parts; the first part is combusted with air from the cathode channel in the afterburner, whereas the others is recirculated and mixed with the inlet fuel stream before being fed to the pre-reformer. The exhaust gas from the afterburner is applied to vaporizing the water stream and preheating the natural gas feed stream. The results reveal that the system efficiency of 85% can be achieved when the cogeneration of heat with power in the SOFC system is considered.

As hydrogen can be produced by a gasification process apart from typical reforming processes, Omosuna et al. [39] investigated the integration of SOFC with biomass gasification for the production of power and heat. Two different systems of 200 kW SOFC-CHP were compared: the first one involves a hot gas cleanup process while the other one uses a cold gas cleanup process. According to the cold process, the anode and cathode effluent is used to preheat the inlet anode and cathode streams, respectively, before being burnt in the afterburner. In contrast, the high temperature effluents from SOFC stack are not applied to the system for the hot process. The results show that the system efficiency of the hot process is higher than that of the cold process because of better heat management in the cleaning process and higher gasification temperature. However, the cost of the hot process is higher than that of the cold process.

In addition to the use of a CHP concept within SOFC systems, the CHP can be designed to combine SOFC with an absorption heating and cooling system. Zink et al. [34] proposed an integrated solid oxide fuel cell (SOFC) absorption heating and cooling system used for buildings. The possibility of the integrated system to provide heating/cooling and/or hot water for buildings was discussed. The preliminary energy and mass balance analysis was performed and the results showed that such a system has the capacity to produce electric power, heating and/or cooling for buildings and the total system efficiencies of higher than 87% in different modes was reported. Another application of the CHP technology in residential applications was reported by Braun et al. [40]. They evaluated the performance of an anode-supported SOFC with micro CHP for residential applications. The influences of fuel types (i.e., hydrogen or methane), methane reforming process (i.e., internal or external reforming), fuel processing with anode recirculation, oxidant processing with cathode recirculation, and the combination of recycle and internal reforming on the system performance were investigated. The results indicated that the maximum efficiency was achieved when the cathode and anode gas recirculation is used along with the internal reforming of methane. The electric efficiencies of the SOFC and the SOFC-CHP are 40% HHV (45% LHV) and 79% (88% LHV), respectively. Recently, Jamsak et al. [41] proposed a hybrid process of an ethanol-fuelled SOFC system and a distillation column (SOFC-DIS). The system consists of three heat exchangers (for preheating feeds), a reformer, and an afterburner. The distillation column was integrated with the SOFC system to purify bioethanol to desired levels of ethanol concentration and recovery. The effluent from the anode and the cathode was burnt in the afterburner and then supplied to the reformer and three heaters. The net remaining heat from the SOFC system was provided to the reboiler of the distillation column. The integrated system provides the maximum electrical power without requiring an additional heat source when the net energy was zero. The effects of ethanol concentration and ethanol recovery on the electrical performance at the self-sustained condition for different fuel utilizations were investigated. It was found that the overall electrical

efficiency and power density are 33.3% (LHV) and  $0.32 \text{ Wcm}^{-2}$ , respectively, at 41% ethanol concentration, 80% fuel utilization and 80% ethanol recovery.

## 5.2 Cogeneration of SOFC: with Gas Turbine (SOFC-GT)

The use of a gas turbine in a combined cycle with an SOFC has been known in concept for many years. However, it is only recently that pressurised operation of SOFC stacks has been demonstrated for prolonged periods, making the SOFC/GT combined cycle system feasible practically [35].

Generally, gas turbines can be connected to the SOFC in two different ways: indirect and direct integrations. In the former, the combustor of the gas turbine is replaced with a heat exchanger in which air from the compressor is heated by the fuel cell exhaust (Figure 13). Under the indirect SOFC-GT hybrid system, the SOFC can be operated at atmospheric conditions. Although, it reduces the sealant requirement in the SOFC stack, the heat exchanger has to operate at very high temperatures and pressure differences. The material requirements in the indirect integration of SOFC-GT are really an issue and hence, it is not generally used. In the latter, the SOFC is directly integrated with the GT by replacing the combustion chamber of the GT as shown in Figure 14.

The pressurized air from the compressor is sent to the cathode and reacts with hydrogen in the reformed gas via electrochemical reactions. The unreacted fuel leaving the anode is combusted with the depleted air in the afterburner. The exhaust at high temperatures is delivered to drive a gas turbine as a bottoming cycle. The remaining heat content of exhaust can be further supplied to other parts in the SOFC system. In this approach, the SOFC operates at high pressure. Although the performance of SOFC is improved due to the high pressure operation, the high pressure gradients between anode and cathode are presented. This may result in the brittleness of the SOFC materials [35]. It was reported that the hybrid SOFC system and gas turbine system can improve an overall electrical efficiency up to 70% [42, 43]. Moreover, the utilization of the exhaust gas from SOFC makes the completeness of fuel conversion in the SOFC stack, leading to a decrease in the size and cost of the SOFC stack [44]. It is noted that apart from a gas turbine, the SOFC system can also be integrated with a steam turbine as a bottoming cycle for generating additional power energy. Although the SOFC and steam turbine hybrid system is less complicated, it offers lower efficiency than the SOFC-GT system [35].

In the past years, there are numerous works devoted to investigate and enhance the performance of the SOFC-GT hybrid system with different configurations. Palsson et al. [43] investigated a SOFC-GT system featuring external pre-reforming and anode gas recycling. The effluent from the anode was partially recycled to supply steam and heat to the external reformer. The rest of the anode effluent was burnt with the cathode effluent in the combustor. The hot gases were then sent to the gas turbine for generating additional electrical power, whereas the exhaust gas from the gas turbine was utilized for preheating the fuel feed stream. The influences of operating parameters such as pressure, air flow rate, fuel flow rate, and air inlet temperature on the system performance were analysed in their work. It was shown that the pressure ratio has a large impact on the system performance and that electrical efficiencies of more than 65% are possible at low pressure ratios. The design and off-design performances of a hybrid system based on the coupling of a recuperated micro gas turbine (MGT) with a high temperature solid oxide fuel cell reactor were presented by Costamagna et al. [45]. The lay-out of an SOFC plant included reformer and SOFC stack while that of MGT was made of the centrifugal compressor, inflow expander, combustion chamber, recuperator, electrical generator, and natural gas compressor. The SOFC model taking into account the influence of the current density, the air utilization factor, the cell operating temperature, etc., was presented and discussed. The operating line, the influence of the micro gas turbine (variable-speed control), and the efficiency behaviour at part load were analysed. The results showed that the hybrid system provided the thermal efficiency of over 60% at design point and always over 50% at part load condition.

Further, Selimovic and Palsson [46] analysed a combination of the networked SOFC with a gas turbine. The SOFC-GT system consisted of two substacks in which the fuel feed was arranged in series whereas air was fed into the stack in series and parallel. When the reactant and air were fed to the SOFC stacks in series, a significant

increase in the system efficiency was observed (about 5%). This is due to the improved cooling of the cell, leading to a smooth temperature profile and higher total fuel utilization in the stack. However, when air streams were fed in parallel, the system efficiency was dropped by 1.5%. Kuchonthara et al. [47] evaluated the combined power generation system consisting of a SOFC and a GT with steam and heat recuperation (HR) by using ASPEN Plus. The effect of steam recuperation (SR) on the overall efficiency of the combined system was investigated by comparing the SOFC-GT during heat and steam recuperation (HSR) against the system during only heat recuperation. It was found that the system with heat and steam recuperation gave higher overall efficiency than the system with only heat recuperation. Möller et al. [48] examined an optimization of a hybrid system combining SOFC and GT with and without CO<sub>2</sub>-capture using a genetic algorithm (GA) optimizer. The desulfurizer unit was installed before pre-reformer in the SOFC-GT system consisting of two SOFC stacks. The reformed gas was equally split between the two stacks and fed to anode in parallel. On the air side, the stacks were connected in series. The remaining fuel in the anode outlet gas was burnt in the gas turbine combustor with supplementary fuel supply. In the SOFC-GT system with CO<sub>2</sub>-capture, the flue gas was cooled and dried in an exhaust gas condenser. The results indicated that the SOFC-GT system integrated with CO<sub>2</sub>-capture exhibited an electrical efficiency above 60%.

Recently, Calise et al. [49] presented the simulation of a full and partial load exergy analysis of a hybrid SOFC-GT power plant. At the full-load operation, the maximum electrical efficiency value of 65.4% was achieved. Three different partial-load strategies were introduced, based on the fuel and air mass flow rate variations. The simulation of the partial load operation of the SOFC-GT hybrid plant showed that the best performance can be obtained in case of the constant fuel to air ratio. However, a lower value of net electrical power (34% of nominal load) could be achieved by reducing the fuel flow rate at the constant air flow rate. Haseli et al. [50] examined the performance of a high-temperature SOFC combined with a conventional recuperative gas turbine (SOFC-GT) plant. The simulation results showed that increasing the turbine inlet temperature resulted in decreasing the thermal efficiency of the cycle, whereas it improved the net specific power output. Moreover, an increase in either the turbine inlet temperature or compression ratio leads to a higher rate of entropy generation within the plant. It was observed that the combustor and SOFC contribute predominantly to the total irreversibility of the system. The SOFC-GT plant and a traditional GT cycle, based on identical operating conditions, were also compared. It was found that the SOFC-GT plant had about 27.8% higher efficiency than the traditional GT plant.

### 5.3 Cogeneration of SOFC: Chemical production approach

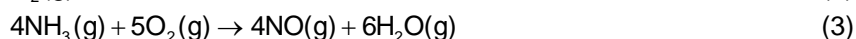
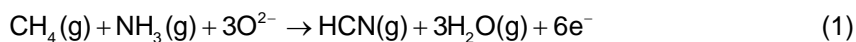
As another approach, SOFC can also be applied for chemical production. Although most of the SOFC studies are aimed at electricity generation, some research groups have considered another potential application of SOFC as an integrated co-generation of chemical production with electric power generation. Farr and Vayenas (1980) first demonstrated this type of operation for the case of NH<sub>3</sub> conversion to NO. The typical concept of SOFC for chemicals and electric power co-generation is illustrated in Figure 15.

This system consists of fuel cell reactor, external load and chemical product recovery unit [51]. Although co-generation systems can operate at low, moderate or high temperature, the use of high temperature operation provides several advantages e.g. minimization of polarization losses and less poisoning by H<sub>2</sub>S. Recently, several chemical co-generation processes for production of inorganic and organic compounds have been proposed from high temperature SOFCs [52-57]. Therefore, the reviews will focus mainly on chemical and electrical power co-generation by high temperature SOFCs. It is noted that the economic evaluation of this cogeneration process is also reviewed.

The firstly experimental evidence of the chemical cogeneration with SOFCs was studied by Farr and Vayenas (1980) [52]. They studied the production of nitric oxide from oxidation of ammonia and recovering energy as electricity. Yttria stabilized zirconia was employed as an electrolyte which was placed between porous Pt electrodes. NH<sub>3</sub> diluted in He at a concentration of 4.59% was fed on the anode side while cathode side was exposed to air. The oxygen ions pass through the electrolyte to the anode, where they react with NH<sub>3</sub>. In the temperature range from 427 to 927 °C, NO was obtained as a primary anodic product with an optimal yield over 60%.

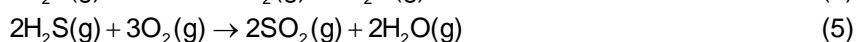
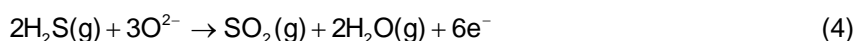
Significant amounts of by-product  $N_2$  were also formed due to the catalytic reaction between  $NH_3$  and  $NO$  on Pt electrode.

Another interesting chemical cogeneration process is the synthesis of hydrogen cyanide, which is widely used for adiponitrile (for Nylon 6/6) synthesis, used in fumigation as insecticide, and in electroplating, metallurgy and photography [53]. The cogeneration system utilizes a mixture of methane and ammonia (diluted in helium) as fuel. The cell was also made with a tube of YSZ enclosed in a quartz tube, containing a porous Pt electrode as the cathode and a porous rhodium and platinum electrode as the anode. Reactions (1) and (2) take place at the anode and cathode, respectively. Reaction (3) presents the overall reaction of this system.

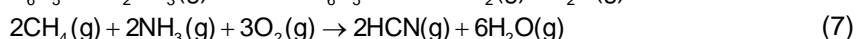
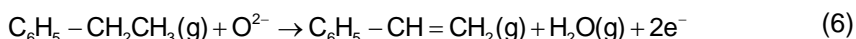


The reactor was operated at 800–1000°C and 1 atm. From their study, the selectivity of HCN exceeds 75% and approximately 0.01 W cm<sup>-2</sup> of power density was delivered. It was also found that the cell could operate without external heat supply for the  $CH_4/NH_3$  feed ratio higher than 1.25 [54].

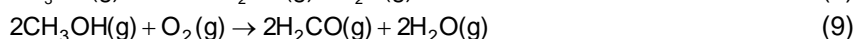
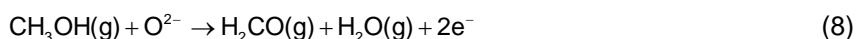
As another interesting case, the oxidation reaction of  $H_2S$  to  $SO_2$  has also been successfully operated [55]. At 650–800°C and atmospheric pressure, hydrogen sulfide was oxidized on the porous Pt electrode. Hydrogen sulfide, diluted in He, was used as fuel and ambient air was used as oxidant. Reaction (4) presents the anode reaction, while the cathode reaction is similar to Reaction (2). Reaction (5) is the overall reaction of this system.



From their experiment, at low current densities (<10 mAcm<sup>-2</sup>) the selectivity to  $SO_2$  remains below 15% and elemental sulfur, (1/2)  $S_2$  (g), is the main product. Nevertheless, at high current densities (>40 mAcm<sup>-2</sup>), the product selectivity to  $SO_2$  increases over 90%. Considering the formation of organic compounds, styrene can be obtained by electrochemical oxidative dehydrogenation of ethylbenzene in SOFC [56], with the anode and overall reactions as following:



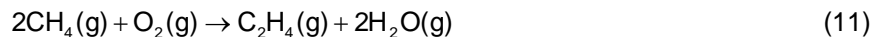
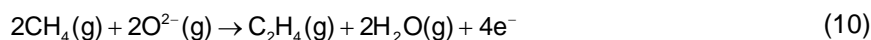
According to the report in that work, styrene, water, and other by-products (mainly  $CO_2$ ) are formed. Nevertheless, although dehydrogenation rates increased with anodic current, total conversion was limited at only 15% or less. The partial oxidation of methanol to formaldehyde, which is an important compound for fertilizer, dyes, disinfectants, germicides and preservatives, is another important industrial reaction that has been reproduced successfully in SOFC [57]. In this case, porous Ag was deposited on both sides of the bottom of YSZ tube and the system was operated at 547–697°C and atmospheric pressure. Methanol vapor diluted in high-purity He was introduced in the inner part of the YSZ tube through the feed. The anode and overall reactions are:



From that work, the power density outputs obtained were about 1mWcm<sup>-2</sup>. Methanol conversion was above 30%, with selectivity to formaldehyde of 85–92%.

As for the conversion of methane, typically, the oxidative coupling of methane has been studied mostly in conventional reactors [58–62]. Nevertheless, there are few studies which apply SOFC for the direct conversion of methane to useful chemicals. For instance, Pujare and Sammells [63] studied the oxidative coupling of methane with SOFC. High selectivity to  $C_2$  hydrocarbon (> 90%) was obtained, although the

methane conversion was relatively low. Otsuka et al. [64] also conducted similar studies over several catalysts (i.e. KF, BaCO<sub>3</sub>, NaCl/MnO<sub>2</sub>, Sm<sub>2</sub>O<sub>3</sub>) deposited on Au-electrode. They found that the most active and selective catalyst was BaCO<sub>3</sub> on Au. Jiang et al. [65] investigated the oxidative coupling of methane to ethylene and C<sub>2</sub> hydrocarbons and reported the yield values up to 88% with the methane conversion up to 97% at 800°C. In their work, two types of anode were used i.e. porous Ag film and porous cermet consisting of Sm<sub>2</sub>O<sub>3</sub> doped with CaO and Ag. Eqs. (10) and (11) present the anode and overall reactions of the above system.

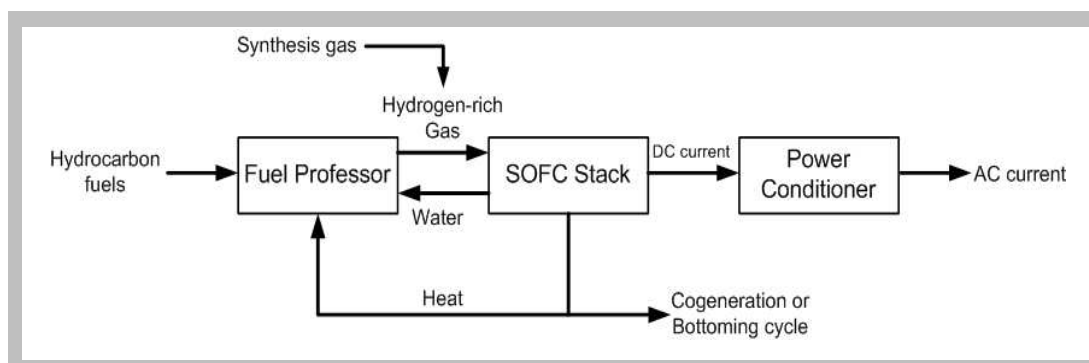


Guo et al. [66] studied the coupling of SOFC with Sr/La<sub>2</sub>O<sub>3</sub>-Bi<sub>2</sub>O<sub>3</sub>-Ag-YSZ membrane for oxidative coupling of methane and revealed that membrane composition had a great effect on the reaction and current generated. The stability of membrane was tested for 62 h and no significant loss of activity was observed (C<sub>2</sub>-selectivity and CH<sub>4</sub> conversion remained relatively constant).

Recently, the kinetic parameters of the reactions at the anode of SOFC (with co-generation of chemical production) were intensely predicted [67] by applying fuel cell type temperature-programmed desorption (FC-TPD) technique to investigate oxygen species [68, 69] and oxygen permeation under the fuel cell operation [70]. The solid oxide fuel cell reactor (SOFCR) for oxidative coupling of methane was considered as a good reactor for C<sub>2</sub> production although the obtained electricity was far from a typical SOFC which solely for electricity generation [71]. The performance of SOFCR for C<sub>2</sub> production was further studied by comparing with conventional fixed bed reactor (FBR), porous membrane reactor (PMR) and mixed ionic and electronic conducting membrane reactor (MIEMR). SOFCR obviously improved C<sub>2</sub> selectivity compared to FBR. However, PMR was superior to the other reactors at low temperature (<1150 K) while MIEMR was attractive at high temperature (>1150 K) [72].

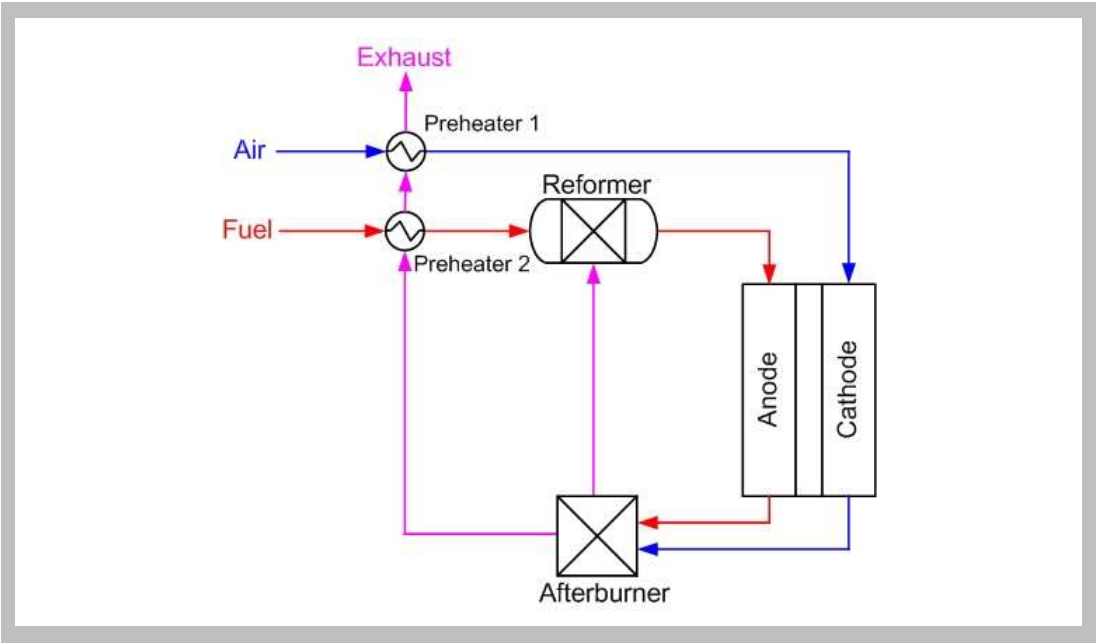
Ishihara et al. [73] studied the co-producing of syngas and electricity by SOFC fueled by methane. Syngas can be used as feedstock for hydrocarbon and methanol manufacture. From their study, the maximum power density of 526mWcm<sup>-2</sup> with synthesis gas yield of 20% can be achieved. Similar investigation was performed by Pillai et al. [74]. They reported that, at 750 °C, the cells produced 0.9 Wcm<sup>-2</sup> with around 90% methane conversion to syngas at a rate of 30 sccm/cm<sup>2</sup>. However, the methane conversion decreased continuously over the first 30–40 h of operation, even though SOFC electrical performance was stable. Importantly, they suggested that an addition of catalyst layer on the anode yielded more stable methane conversion to syngas.

According to the economic analysis of SOFC for chemical cogeneration, until now, very limited works have been reported. Spillman et al. [75] developed a simplified expression to determine the most profitable operation among the various mode i.e. reverse electrolysis, solely fuel cell for electricity generation, chemical cogeneration and forward electrolysis. They concluded that as long as chemical product is more value than electricity, operation in direct electrolysis is more attractive than cogeneration. Vayenas et al. [76] proposed the index for evaluating the relative profitability of SOFC chemical cogeneration comparing to chemical reactor at same product capacity and composition. Only SOFC reactor using inexpensive materials with exothermic reaction might be beneficial. The results showed the H<sub>2</sub>SO<sub>4</sub> and HNO<sub>3</sub> cogeneration possibly were advantageous while ethylene oxide and formaldehyde production were not.

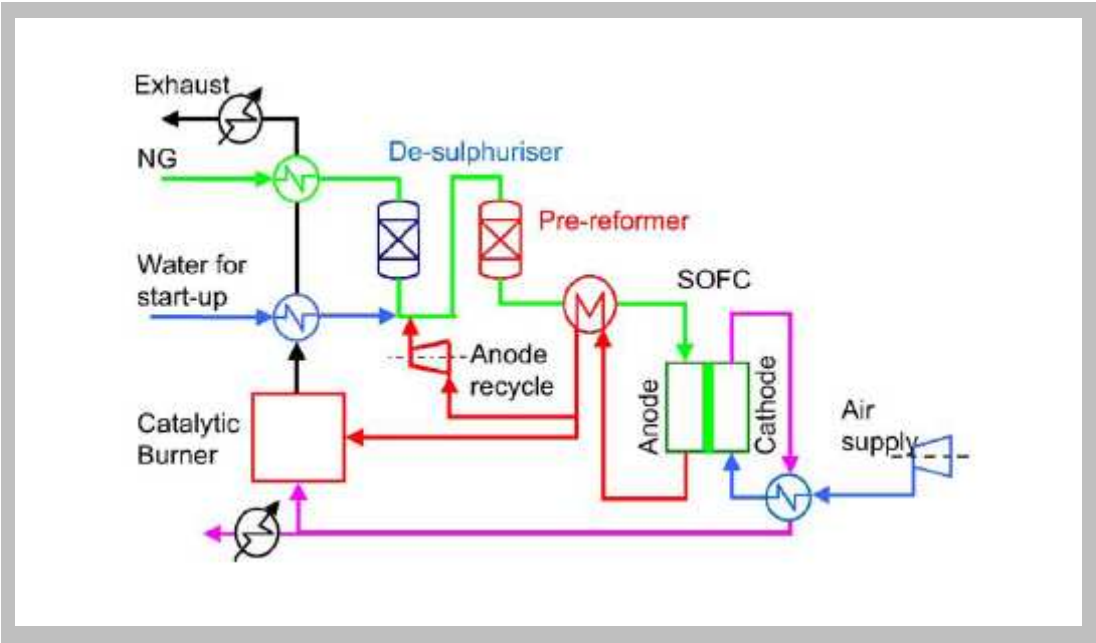


**Figure 10**  
Schematic diagram of a typical SOFC system.

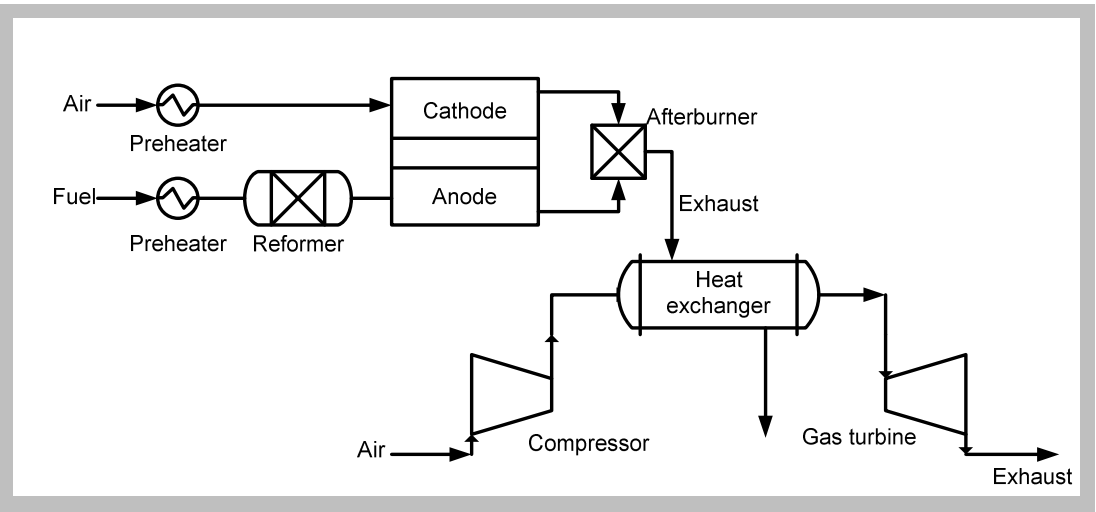
**Figure 11**  
Simplified SOFC system with combined heat and power.

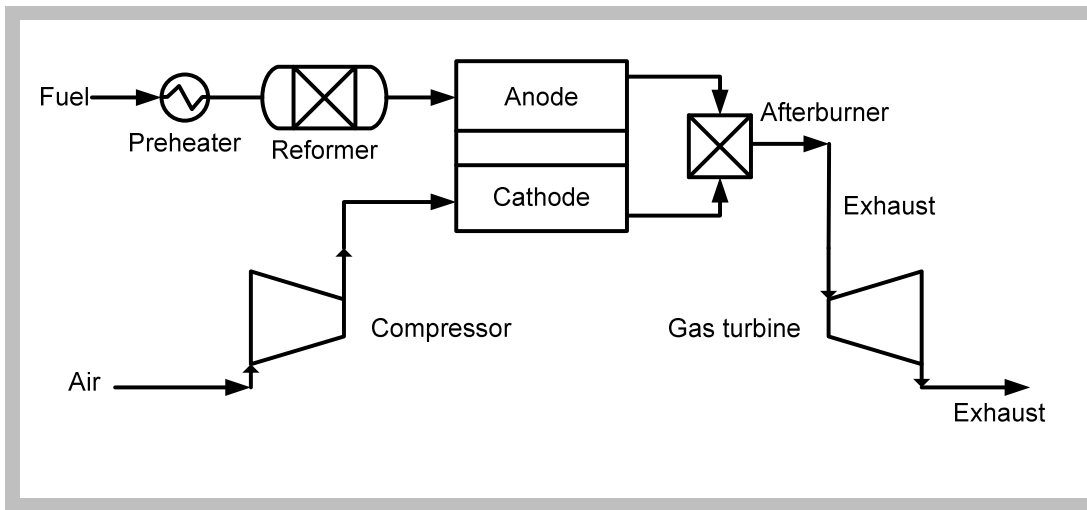


**Figure 12**  
Integration of SOFC system with desulphuriser unit [38].

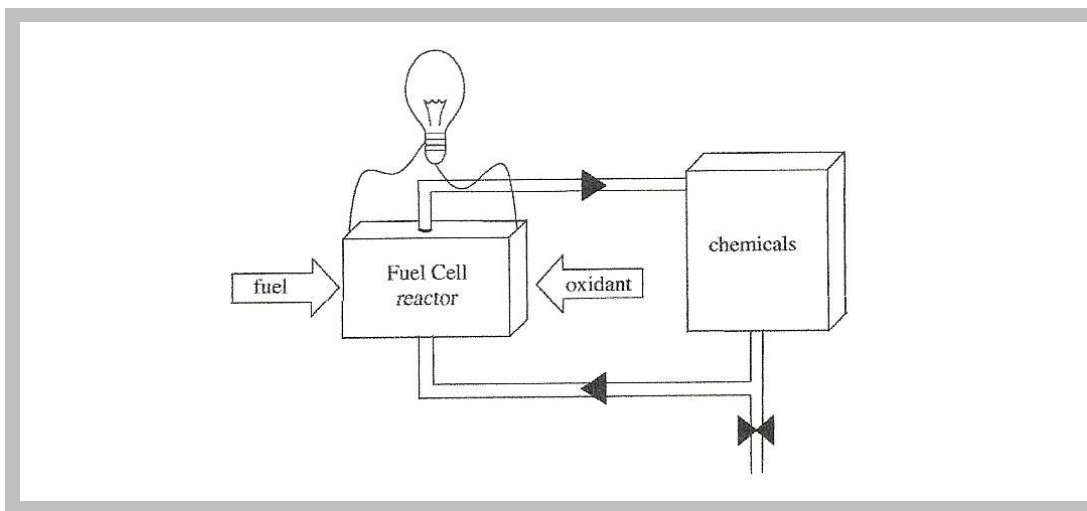


**Figure 13**  
Indirect integration of SOFC and GT.





**Figure 14**  
Indirect integration of SOFC and GT.



**Figure 15**  
Principles of operation of fuel cell for generating chemicals and energy [51].

## VI. Conclusions

Solid Oxide Fuel Cell (SOFC) is a type of fuel cell that appears to be one of the most promising fuel cell systems. The main advantage of SOFC over other types of fuel cell is its tolerance to the impurities of inlet fuels; this means various types of fuel can be applied with SOFC. The main components of a single cell are electrolyte, cathode and anode. When single cells are stacked together to generate more power, it requires two more cell components of interconnect and sealant. For SOFC electrolyte material, yttria-stabilized zirconia (YSZ) is the most widely used. It is noted that scandia stabilized zirconia (ScSZ) show higher conductivity with better stability than YSZ, however, its limitation is the high price and low availability. As for SOFC anode material, the most common anode material is a porous Ni-YSZ cermet, in which nickel provides the electronic conductivity and YSZ provides the oxygen-ion conduction. For cathode, the most common type of cathode material is perovskite-based  $\text{LaMnO}_3$ . Furthermore, strontium was normally used to dope with  $\text{LaMnO}_3$  (become  $(\text{La}_{1-x}\text{Sr}_x)\text{MnO}_3$  (LSM)), which can enhance the electronic conductivity. At the present, the state-of-the-art SOFC cell components materials are i.e. 8 mol % yttria stabilized zirconia (YSZ, as electrolyte), Sr-substituted  $\text{LaMnO}_3$  (LSM, as cathode), Ni-YSZ cermet (as anode), Ca-substituted  $\text{LaCrO}_3$  (LCR) or metallic alloys (as interconnect) and glass or glass-ceramic (as sealants).

According to the design and operation of SOFC, currently, there are two main SOFC designs i.e. tubular and planer designs. The main advantage for tubular design is no gas-tight seal problem, but this design needs to consider the cell internal resistance and the gas diffusion limitation. As for the operation, internal reforming operation seems to be the interesting option for SOFC due to the achievement of high thermal and electrical efficiency, nevertheless, the temperature gradient along SOFC system must be carefully controlled.

Due to the high temperature operation of SOFC, the utilization of heat from SOFC system can significantly improve the efficiency of SOFC system. This brings the SOFC system to a combined process with other types of bottoming cycles such as a gas turbine (GT) or the cogeneration of heat with electricity (a combined heat and power system). Furthermore, as



another approach, SOFC can also be applied as the integrated cogeneration of chemical production with electric power generation. From this cogeneration, valuable products can be generated along with electricity from SOFC system.

## REFERENCES

- [1] N. Q. Minh and T. Takahashi, *Science and Technology of Ceramic Fuel Cells*. Amsterdam: Elsevier Science, 1995.
- [2] N. Q. Minh, "Ceramic Fuel Cells," *Journal of the American Ceramic Society*, vol. 76, pp. 563-588, 1993.
- [3] P. Aguiar, N. Lapena-Rey, D. Chadwick, and L. Kershenbaum, "Improving catalyst structures and reactor configurations for autothermal reaction systems: application to solid oxide fuel cells," *Chemical Engineering Science*, vol. 56, pp. 651-658, 2001.
- [4] A. L. Lee, R. F. Zabransky, and W. J. Huber, "Internal reforming development for solid oxide fuel cells," *Industrial & Engineering Chemistry Research*, vol. 29, pp. 766-773, 1990.
- [5] R. Bove, "Solid Oxide Fuel Cells: Principles, Designs and State-of-the-Art in Industries," in *Recent Trends in Fuel Cell Science and Technology*, vol. 267-285, S. Basu, Ed.: Springer New York, pp. 267-285, 2007.
- [6] S. C. Singhal, "Advances in solid oxide fuel cell technology," *Solid State Ionics*, vol. 135, pp. 305-313, 2000.
- [7] T. Kawada and J. Mizusaki, "Current electrolytes and catalyst : Chapter 70," in *Handbook of Fuel Cells: Fundamentals, Technology, Applications*, W. Vielstich, A. Lamm, and H. A. Gasteiger, Eds.: John Wiley & Sons, pp. 987-1001, 2003.
- [8] J. W. Fergus, "Electrolytes for solid oxide fuel cells," *Journal of Power Sources*, vol. 162, pp. 30-40, 2006.
- [9] R. N. Basu, "Materials for Solid Oxide Fuel Cells," in *Recent Trends in Fuel Cell Science and Technology*, S. Basu, Ed.: Springer New York, pp. 286-331, 2007.
- [10] J. Fergus, "Materials challenges for solid-oxide fuel cells," *JOM Journal of the Minerals, Metals and Materials Society*, vol. 59, pp. 56-62, 2007.
- [11] A. V. Joshi, J. J. Steppan, D. M. Taylor, and S. Elangovan, "Solid Electrolyte Materials, Devices, and Applications," *Journal of Electroceramics*, vol. 13, pp. 619-625, 2004.
- [12] J. W. Fergus, "Oxide anode materials for solid oxide fuel cells," *Solid State Ionics*, vol. 177, pp. 1529-1541, 2006.
- [13] M. Gong, X. Liu, J. Trembly, and C. Johnson, "Sulfur-tolerant anode materials for solid oxide fuel cell application," *Journal of Power Sources*, vol. 168, pp. 289-298, 2007.
- [14] Z. Cheng and M. Liu, "Characterization of sulfur poisoning of Ni-YSZ anodes for solid oxide fuel cells using *in situ* Raman microspectroscopy," *Solid State Ionics*, vol. 178, pp. 925-935, 2007.
- [15] Y. M. Choi, C. Compson, M. C. Lin, and M. Liu, "Ab initio analysis of sulfur tolerance of Ni, Cu, and Ni-Cu alloys for solid oxide fuel cells," *Journal of Alloys and Compounds*, vol. 427, pp. 25-29, 2007.
- [16] G. Stochniol, E. Syskakis, and A. Naoumidis, "Chemical Compatibility between Strontium-Doped Lanthanum Manganite and Yttria-Stabilized Zirconia," *Journal of the American Ceramic Society*, vol. 78, pp. 929-932, 1995.
- [17] K. Kleveland, M. A. Einarsrud, C. R. Schmidt, S. Shamsli, S. Faaland, K. Wiik, and T. Grande, "Reactions between Strontium-Substituted Lanthanum Manganite and Yttria-Stabilized Zirconia: II, Diffusion Couples," *Journal of the American Ceramic Society*, vol. 82, pp. 729-734, 1999.
- [18] J. M. Ralph, C. Rossignol, and R. Kumar, "Cathode Materials for Reduced-Temperature SOFCs," *Journal of The Electrochemical Society*, vol. 150, pp. A1518-A1522, 2003.
- [19] J. W. Fergus, "Metallic interconnects for solid oxide fuel cells," *Materials Science and Engineering A*, vol. 397, pp. 271-283, 2005.
- [20] J. W. Fergus, "Sealants for solid oxide fuel cells," *Journal of Power Sources*, vol. 147, pp. 46-57, 2005.
- [21] J. T. Brown, "presented at a meeting of the DOE/AFCWG." WE, R&D Center. 1310 Beulah Rd., Pittsburgh, PA, 1984.
- [22] S. C. Singhal, in *Proceedings of the Second International Symposium on Solid Oxide Fuel Cells.*, F. Gross, P. Zegers, S. C. Singhal, and O. Yamamoto, Eds. Luxembourg: Office For Official Publication of the European Communities, p. 557, 1991.
- [23] Y. Ohno, S. Nagata, and H. Sato, in *Proceedings of the 15th Intersociety Energy Conversion Engineering Conference, Seattle, 18--22 August, 1980*: American Institute of Aeronautics and Astronautics, pp. 881-885, 1980.
- [24] A. O. Isenberg, in *Proceedings of the Symposium on Electrode Materials and Processes for Energy Conversion and Storage.*, J. D. E. McIntyre, S. Srinivasan, and F. G. Will, Eds. Pennington, Society, p. 682, 1977.
- [25] D. H. Archer, R. L. Zahradnik, E. F. Sverdrup, W. A. English, L. Elikan, and J. J. Alles, in *Proceedings of the 18th Annual Power Sources Conference.*: PSC Publication Committee, Red Bank, NJ, p. 36, 1964.
- [26] F. J. Rohr, in *Proceedings of the Workshop on High-Temperature Solid Oxide Fuel Cells*, vol. Rept. No. BNL 50756, H. S. Isaacs, S. Srinivasan, and I. L. Harry, Eds.: Brookhaven National Laboratory, Upton, NY, pp. 122-131, 1978.
- [27] J. P. Ackerman and J. E. Young, "Solid oxide fuel cell having monolithic core," *US Patent 4476198*, October 9, 1984.
- [28] R. B. Poeppel and J. T. Dusek, "Solid oxide fuel cell having monolithic cross flow core and manifolding," *US Patent 4476196*, October 9, 1984.
- [29] J. R. Rostrup-Nielsen and L. J. Christiansen, "Internal steam reforming in fuel cells and alkali poisoning," *Applied Catalysis A: General*, vol. 126, pp. 381-390, 1995.
- [30] C. M. Finnerty, N. J. Coe, R. H. Cunningham, and R. M. Ormerod, "Carbon formation on and deactivation of nickel-based/zirconia anodes in solid oxide fuel cells running on methane," *Catalysis Today*, vol. 46, pp. 137-145, 1998.
- [31] G. Hoogers, *Fuel Cell Technology Handbook*: CRC press, 2003.
- [32] S. Campanari, "Thermodynamic model and parametric analysis of a tubular SOFC module," *Journal of Power Sources*, vol. 92, pp. 26-34, 2001.
- [33] E. Riensche, U. Stimming, and G. Unverzagt, "Optimization of a 200 kW SOFC cogeneration power plant: Part I: Variation of process parameters," *Journal of Power Sources*, vol. 73, pp. 251-256, 1998.
- [34] F. Zink, Y. Lu, and L. Schaefer, "A solid oxide fuel cell system for buildings," *Energy Conversion and Management*, vol. 48, pp. 809-818, 2007.
- [35] J. Larminie and A. Dicks, *Fuel Cell Systems Explained*, 2 ed: John Wiley & Sons, 2003.
- [36] S. C. Singhal and K. Kendall, *High-temperature Solid Oxide Fuel Cells: Fundamentals, Design and Applications*: Elsevier Science, 2004.
- [37] S. H. Chan, C. F. Low, and O. L. Ding, "Energy and exergy analysis of simple solid-oxide fuel-cell power systems," *Journal of Power Sources*, vol. 103, pp. 188-200, 2002.
- [38] E. Fontell, T. Kivisaari, N. Christiansen, J. B. Hansen, and J. Palsson, "Conceptual study of a 250 kW planar SOFC system for CHP application," *Journal of Power Sources*, vol. 131, pp. 49-56, 2004.
- [39] A. O. Omosun, A. Bauen, N. P. Brandon, C. S. Adjiman, and D. Hart, "Modelling system efficiencies and costs of two biomass-fuelled SOFC systems," *Journal of Power Sources, Selected papers presented at the Eighth Grove Fuel Cell Symposium*, vol. 131, pp. 96-106, 2004.
- [40] R. J. Braun, S. A. Klein, and D. T. Reindl, "Evaluation of system configurations for solid oxide fuel cell-based micro-combined heat and power generators in residential applications," *Journal of Power Sources, Special issue including selected papers from the 6th International Conference on Lead-Acid Batteries (LABAT 2005, Varna, Bulgaria) and the 11th Asian Battery Conference (11 ABC, Ho Chi Minh City, Vietnam) together with regular papers*, vol. 158, pp. 1290-1305, 2006.

- [41] W. Jamsak, S. Assabumrungrat, P. L. Douglas, E. Croiset, N. Laosiripojana, R. Suwanwarangkul, and S. Charojrochkul, "Thermodynamic assessment of solid oxide fuel cell system integrated with bioethanol purification unit," *Journal of Power Sources, Hybrid Electric Vehicles*, vol. 174, pp. 191-198, 2007.
- [42] M. Dokiya, "SOFC system and technology," *Solid State Ionics*, vol. 152-153, pp. 383-392, 2002.
- [43] J. Palsson, A. Selimovic, and L. Sjunnesson, "Combined solid oxide fuel cell and gas turbine systems for efficient power and heat generation," *Journal of Power Sources*, vol. 86, pp. 442-448, 2000.
- [44] M. Granovskii, I. Dincer, and M. A. Rosen, "Performance comparison of two combined SOFC-gas turbine systems," *Journal of Power Sources*, vol. 165, pp. 307-314, 2007.
- [45] P. Costamagna, L. Magistri, and A. F. Massardo, "Design and part-load performance of a hybrid system based on a solid oxide fuel cell reactor and a micro gas turbine," *Journal of Power Sources*, vol. 96, pp. 352-368, 2001.
- [46] A. Selimovic and J. Palsson, "Networked solid oxide fuel cell stacks combined with a gas turbine cycle," *Journal of Power Sources*, vol. 106, pp. 76-82, 2002.
- [47] P. Kuchonthara, S. Bhattacharya, and A. Tsutsumi, "Energy recuperation in solid oxide fuel cell (SOFC) and gas turbine (GT) combined system," *Journal of Power Sources*, vol. 117, pp. 7-13, 2003.
- [48] B. F. Möller, J. Arriagada, M. Assadi, and I. Potts, "Optimisation of an SOFC/GT system with CO<sub>2</sub>-capture," *Journal of Power Sources, Selected papers presented at the Eighth Grove Fuel Cell Symposium*, vol. 131, pp. 320-326, 2004.
- [49] F. Calise, A. Palombo, and L. Vanoli, "Design and partial load exergy analysis of hybrid SOFC-GT power plant," *Journal of Power Sources*, vol. 158, pp. 225-244, 2006.
- [50] Y. Haseli, I. Dincer, and G. F. Naterer, "Thermodynamic modeling of a gas turbine cycle combined with a solid oxide fuel cell," *International Journal of Hydrogen Energy*, vol. 33, pp. 5811-5822, 2008.
- [51] F. Alcaide, P.L. Cabot, and E. Brillas, "Fuel cells for chemicals and energy cogeneration," *Journal of Power Sources*, vol. 153, pp. 47-60, 2006.
- [52] R. D. Farr and C. G. Vayenas, "Ammonia High Temperature Solid Electrolyte Fuel Cell," *Journal of The Electrochemical Society*, vol. 127, pp. 1478-1483, 1980.
- [53] N. Kiratzis and M. Stoukides, "The Synthesis of Hydrogen Cyanide in a Solid Electrolyte Fuel Cell," *Journal of The Electrochemical Society*, vol. 134, pp. 1925-1929, 1987.
- [54] E.A. McKenna, A. Othoneos, N. Kiratzis, and M. Stoukides, "Synthesis of hydrogen cyanide in a solid-electrolyte-cell reactor," *Electrochem. Soc. Vol. 134*, pp. 1925-1929, 1987.
- [55] I. V. Yentekakis and C. G. Vayenas, "Chemical Cogeneration in Solid Electrolyte Cells," *Journal of The Electrochemical Society*, vol. 136, pp. 996-1002, 1989.
- [56] J. N. Michaels and C. G. Vayenas, "Styrene Production from Ethylbenzene on Platinum in a Zirconia Electrochemical Reactor," *Journal of The Electrochemical Society*, vol. 131, pp. 2544-2550, 1984.
- [57] S. Neophytides and C. G. Vayenas, "Chemical Cogeneration in Solid Electrolyte Cells," *Journal of The Electrochemical Society*, vol. 137, pp. 839-845, 1990.
- [58] J. A. Hugill, F. W. A. Tillemans, J. W. Dijkstra, and S. Spoelstra, "Feasibility study on the co-generation of ethylene and electricity through oxidative coupling of methane," *Applied Thermal Engineering*, vol. 25, pp. 1259-1271, 2005.
- [59] H. Zhang, J. Wu, B. Xu, and C. Hu, "Simultaneous Production of Syngas and Ethylene from Methane by Combining its Catalytic Oxidative Coupling over Mn/Na<sub>2</sub>WO<sub>4</sub>/SiO<sub>2</sub> with Gas Phase Partial Oxidation," *Catalysis Letters*, vol. 106, pp. 161-165, 2006.
- [60] R. A. Periana, O. Mironov, D. Taube, G. Bhalla, and C. J. Jones, "Homogeneous, catalytic, oxidative coupling of methane to acetic acid in one step," *Topics in Catalysis*, vol. 32, pp. 169-174, 2005.
- [61] J. Wang, L. Chou, B. Zhang, H. Song, J. Zhao, J. Yang, and S. Li, "Comparative study on oxidation of methane to ethane and ethylene over Na<sub>2</sub>WO<sub>4</sub>-Mn/SiO<sub>2</sub> catalysts prepared by different methods," *Journal of Molecular Catalysis A: Chemical*, vol. 245, pp. 272-277, 2006.
- [62] N. A. S. Amin and S. E. Pheng, "Influence of process variables and optimization of ethylene yield in oxidative coupling of methane over Li/MgO catalyst," *Chemical Engineering Journal*, vol. 116, pp. 187-195, 2006.
- [63] N. U. Pujare and A. F. Sammells, "Methane Activation to C[<sub>sub</sub>2] Hydrocarbon Species in Solid Oxide Fuel Cell," *Journal of The Electrochemical Society*, vol. 135, pp. 2544-2545, 1988.
- [64] K. Otsuka, K. Suga, and I. Yamanaka, "Oxidative coupling of methane applying a solid oxide fuel cell system," *Catalysis Today*, vol. 6, pp. 587-592, 1990.
- [65] Y. Jiang, I. V. Yentekakis, and C. G. Vayenas, "Methane to ethylene with 85 percent yield in a gas recycle electrocatalytic reactor-separator," *Science*, vol. 264, pp. 1563-1566, 1994.
- [66] X. M. Guo, K. Hidayat, and C. B. Ching "An Experimental Study of Oxidative Coupling of Methane in a Solid Oxide Fuel Cell With 1 wt% Sr/La<sub>2</sub>O<sub>3</sub>-Bi<sub>2</sub>O<sub>3</sub>-Ag-YSZ Membrane," *Korean Journal of Chemical Engineering*, vol. 15, pp. 469-473, 1998.
- [67] W. Kiatkittipong, T. Tagawa, S. Goto, S. Assabumrungrat, and P. Prasertthdam, "Oxidative Coupling of Methane in the LSM/YSZ/LaAlO SOFC Reactor," *Journal of Chemical Engineering of Japan*, vol. 37, pp. 1461-1470, 2004.
- [68] W. Kiatkittipong, T. Tagawa, S. Goto, S. Assabumrungrat, and P. Prasertthdam, "TPD study in LSM/YSZ/LaAlO system for the use of fuel cell type reactor," *Solid State Ionics*, vol. 166, pp. 127-136, 2004.
- [69] T. Tagawa, K. Kuroyanagi, S. Goto, S. Assabumrungrat, and P. Prasertthdam, "Selective oxidation of methane in an SOFC-type reactor: effect of applied potential," *Chemical Engineering Journal*, vol. 93, pp. 3-9, 2003.
- [70] W. Kiatkittipong, T. Tagawa, S. Goto, S. Assabumrungrat, and P. Prasertthdam, "Oxygen transport through LSM/YSZ/LaAlO system for use of fuel cell type reactor," *Chemical Engineering Journal*, vol. 106, pp. 35-42, 2005.
- [71] W. Kiatkittipong, S. Goto, T. Tagawa, S. Assabumrungrat, and P. Prasertthdam, "Simulation of Oxidative Coupling of Methane in Solid Oxide Fuel Cell Type Reactor for C<sub>2</sub> Hydrocarbon and Electricity Co-Generation," *Journal of Chemical Engineering of Japan*, vol. 38, pp. 841-848, 2005.
- [72] W. Kiatkittipong, T. Tagawa, S. Goto, S. Assabumrungrat, K. Silpasup, and P. Prasertthdam, "Comparative study of oxidative coupling of methane modeling in various types of reactor," *Chemical Engineering Journal*, vol. 115, pp. 63-71, 2005.
- [73] T. Ishihara, T. Yamada, T. Akbay, and Y. Takita, "Partial oxidation of methane over fuel cell type reactor for simultaneous generation of synthesis gas and electric power," *Chemical Engineering Science, International symposium on multifunctional reactors*, vol. 54, pp. 1535-1540, 1999.
- [74] M. Pillai, D. Bierschenk, and S. Barnett, "Electrochemical Partial Oxidation of Methane in Solid Oxide Fuel Cells: Effect of Anode Reforming Activity," *Catalysis Letters*, vol. 121, pp. 19-23, 2008.
- [75] R. W. Spillman, R. M. Spotnitz, and J. T. Lundquist Jr., *Chemtech*, vol. 14, pp. 176-183, 1984.
- [76] C. G. Vayenas, S. I. Bebelis, and C. C. Kyriazis, *Chemtech*, vol. 21, pp. 422-428, 1991.
- [77] M. Stoukides, "Electrochemical studies of methane activation," *Journal of Applied Electrochemistry*, vol. 25, pp. 899-912, 1995.